

No. 2 1977

issued quarterly

Technical Review

To Advance Techniques in Acoustical, Electrical and Mechanical Measurement

**AUTOMATIC-REV. TIME
PVC MODULUS AT HIGH FREQUENCIES**

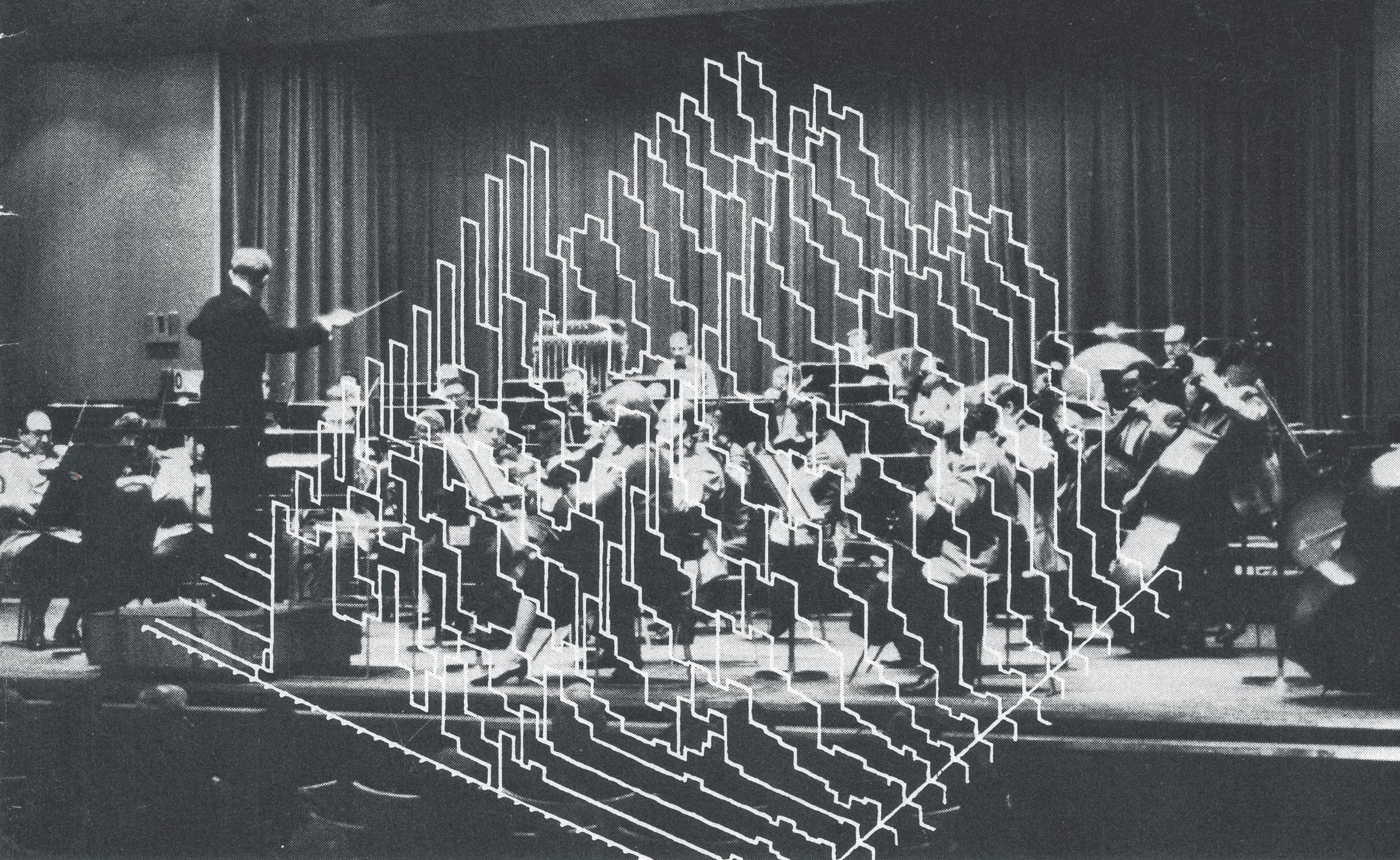

Brüel & Kjær

**PREVIOUSLY ISSUED NUMBERS OF
BRÜEL & KJÆR TECHNICAL REVIEW**

- 1-1977 Digital Filters in Acoustic Analysis Systems.
An Objective Comparison of Analog and Digital Methods
of Real-Time Frequency Analysis.
- 4-1976 An Easy and Accurate Method of Sound Power Measure-
ments.
Measurement of Sound Absorption of rooms using a Re-
ference Sound Source.
- 3-1976 Registration of Voice Quality.
Acoustic Response Measurements and Standards for
Motion-Picture Theatres.
- 2-1976 Free-Field Response of Sound Level Meters.
High Frequency Testing of Gramophone Cartridges using
an Accelerometer.
- 1-1976 Do We Measure Damaging Noise Correctly?
- 4-1975 On the Measurement of Frequency Response Functions.
- 3-1975 On the Averaging Time of RMS Measurements
(continuation).
- 2-1975 On the Averaging Time of RMS Measurements
Averaging Time of Level Recorder Type 2306 and "Fast"
and "Slow" Response of Level Recorders 2305/06/07
- 1-1975 Problems in Telephone Measurements.
Proposals for the Measurement of Loudness Ratings
of Operators' Headsets.
Comparison of Results obtained by Subjective
Measuring Methods.
Repeatabilities in Electro-Acoustic Measurements on
Telephone Capsules.
Stable Subset Measurements with the 73 D
Vibration Testing of Telephone Equipment.
- 4-1974 Underwater Impulse Measurements.
A Comparison of ISO and OSHA Noise Dose
Measurements.
Sound Radiation from Loudspeaker System with the
Symmetry of the Platonic Solids.
- 3-1974 Acoustical Investigation of an Impact Drill.
Measurement of the Dynamic Mass of the Hand-arm
System.
- 2-1974 On Signal/Noise Ratio of Tape Recorders.
On the Operating Performance of the Tape Recorder
Type 7003 in a Vibrating Environment.

(Continued on cover page 3)

TECHNICAL REVIEW

No. 2 — 1977

Contents

Automated Measurements of Reverberation Time using the Digital Frequency Analyzer Type 2131 by R. Upton	3
Measurement of Elastic Modulus and Loss Factor of PVC at High Frequencies by O. B. Sørensen and V. Tarnow	19
News from the Factory	28

Automated Measurements of Reverberation Time using the Digital Frequency Analyzer Type 2131

by

R. Upton

ABSTRACT

This article describes how reverberation time measurements can be carried out with the use of the Digital Frequency Analyzer Type 2131 and a desk top calculator such as the Hewlett Packard Calculator 9825A. Considerable time saving is achieved on account of parallel filtering and therefore large amounts of data can be processed, as is normally required in practice. A fully automated system is also outlined, where the noise generator is controlled by the calculator. With this method multiple slopes in the reverberation decay curves can be detected.

SOMMAIRE

Cet article décrit l'emploi de l'Analyseur Numérique de Fréquence Type 2131 et d'un calculateur de bureau comme le calculateur Hewlett Packard 9825A pour les mesures de temps de réverbération. Ce système permet des gains de temps considérables grâce au filtrage en parallèle et, par suite, on peut traiter un grand nombre de données, ce qui est normalement nécessaire en pratique. Un système entièrement automatique est aussi décrit, dans lequel le générateur de bruit est commandé par le calculateur. Grâce à cette méthode, on peut détecter la présence de plusieurs pentes dans la courbe de réverbération.

ZUSAMMENFASSUNG

In diesem Artikel wird beschrieben, wie die Nachhallzeit-Messung mit Hilfe des Echtzeit-Terz/Oktav-Analysators Typ 2131 und einem Tischrechner wie Hewlett Packard 9825A erstellt werden kann. Durch die parallele Filterung erreicht man eine beträchtliche Zeitersparnis und daher können viele Daten errechnet werden, wie es normalerweise in der Praxis gewünscht wird. Es wird ein vollautomatisches System beschrieben, wobei der Rauschgenerator mit dem Rechner gesteuert wird. Mit dieser Methode können verschiedene Steigungen in der Flanke der Nachhallkurve ermittelt werden.

Introduction

Historically, the method used to measure reverberation time has been to excite the room of interest with an impulse, with broadband noise, or with a warble tone, and to then record the decay of the sound field using an instrument such as a Level Recorder. The reverberation time, which is defined as being the time taken for the sound field to decay by 60 dB, is measured from the decay curve obtained. Since reverberation time is variable with frequency, it is normally measured in octave or in 1/3 octave bands. Further, it is normal to obtain and to average many results in each band.

Although it is simple by nature, the above measurement can become extremely tedious, due to the large amounts of data which can be generated. It is not uncommon to obtain and to average more than twenty results in each band. In a 1/3 octave band measurement over the range of, say, 125 Hz to 10 kHz, this would require the generation of 400 separate decay curves or more. The number of decay curves required multiplies further when, as is normally the case, different microphone positions are used.

Several attempts have been made to automate the reverberation time measurement. One very attractive idea has been to use a real-time 1/3 octave analyzer with a computer, which could make automatic measurements in parallel. Such a combination could be used either on-line, e.g. in a closed loop system in a reverberation room or off-line, e.g. with tape recorded decays. The main attraction, however, with respect to other solutions to the automated reverberation time measurement problem is that the system need not be dedicated. When they are not being used for reverberation time measurements, the real-time analyzer and computer can be used for a host of other applications, either as parts of other systems or as stand alone instruments.

Unfortunately, reverberation time measurement places such stringent requirements on the real-time analyzer that except in one or two isolated cases, it has not really been possible to implement the above solution. Firstly, the analyzer must have sufficient dynamic range to give a usable measurement window. Secondly, it must be possible to select a short enough averaging time, such that the analyzer can accurately follow a decay which might only last a few hundred milliseconds. Finally, the analyzer must be able to transmit information fast enough about the decay to a computer such that the computer can calculate the reverberation times with sufficient accuracy. It was only with the introduction of the Digital Frequency Analyzer Type 2131 that a real-time anal-

alyzer fulfilling all of these requirements became available.

Measurement of Reverberation Time using the 2131

A typical system for reverberation time measurement using the 2131 is shown in Fig.1. Note that the system uses a desk-top calculator rather than a computer or a minicomputer. Where the calculator is equipped with an IEC or IEEE compatible interface, it may be directly connected to the 2131, via the IEC interface of the 2131. This lack of any special interfacing requirements coupled with its convenience of use makes the calculator preferable to the minicomputer or computer. Further, other IEC or IEEE compatible instruments can be added into the system to enlarge it.

The calculator used in the system of Fig.1 is a Hewlett-Packard 9825A. This calculator is chosen for its operating speed. Since the 2131 is capable of transmitting spectra at 44 ms intervals, for the measurement of shorter reverberation times, it is important that the calculator be capable of accepting every spectrum transmitted. The 9825A fulfills this requirement. Another calculator, the Tektronix 4051, might also be used, which has the advantage of having a built in visual display unit. The minimum time interval between spectra now becomes approximately 180 ms, however, meaning that the minimum reverberation time measurable using a 2131/4051 system would be in excess of 1 second.

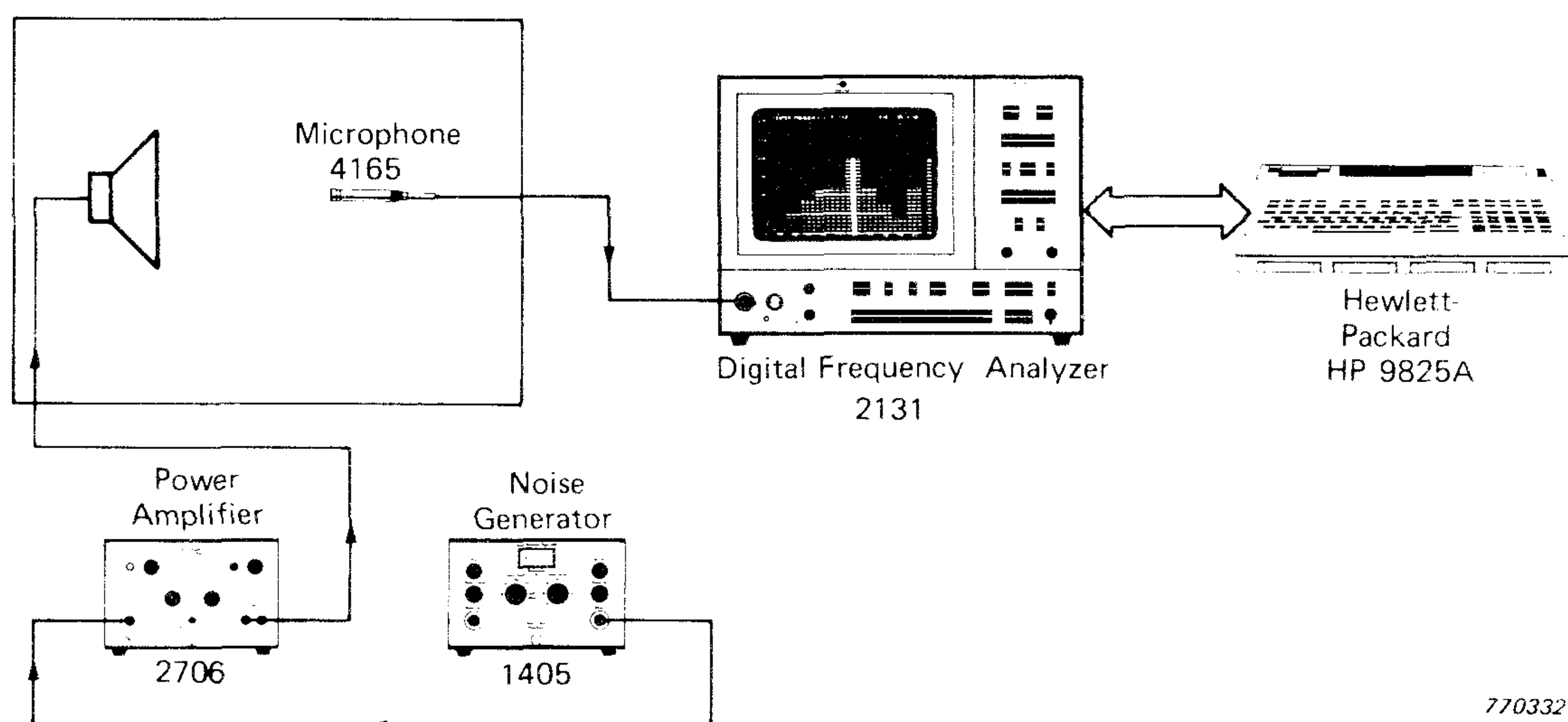

Fig.1. Simplified system for reverberation time measurements

The system operates using the interrupted noise method. The room of interest is excited using pink noise, and the resulting sound field is monitored by the 2131. Just before the noise generator is manually switched off, an instruction is entered via the 9825A keyboard to begin the transmission of spectra from the 2131 to the 9825A. The time interval between the spectra is selected according to the expected magnitude of the reverberation times. Use of the minimum time interval, 44 ms, is only necessary for measurements in the region below 1 second, and where longer times are to be expected, the read-in interval can be increased. Further, it should be remembered that the number of spectra which the 9825A can hold in its memory is limited by the memory size itself, (this is approximately 70 spectra for a 24 K memory), and quite obviously, the 2131 should continue to transmit spectra and the 9825A to store them until after the sound field has decayed in all $1/3$ octave bands and reached the background noise level. Hence, the read-in time interval used is influenced by the maximum as well as the minimum reverberation time to be measured.

At the end of the above process, after the noise generator has been switched off, and the sound field has decayed and reached the background level, the 9825A will hold in its memory the spectra transmitted to it from the 2131, before, during, and after the decay. Each spectrum represents a "time-slice" through the decay, i.e. it gives the level in each octave or $1/3$ octave channel at the point in time corresponding to when the spectrum was output from the 2131. Hence, when all of the spectra output are viewed together, they give a three-dimensional landscape of the decay in terms of amplitude against frequency against time, see Appendix.

From here, it is a relatively simple matter to calculate the reverberation times, since when each frequency channel of the landscape is viewed individually, it shows the variation of the level in that channel with time, as a series of points separated by the time interval used between reading in the spectra from the 2131. Hence, those points pertaining to the reverberation decay can be taken, and the reverberation time calculated using a best line of fit technique. This is repeated for each channel of interest. Thereafter, further reverberation decays can be similarly treated, and a statistical analysis performed on the results.

Given a read-in interval of 44 ms, and an averaging time on the 2131 set to $1/32$ s, then the shortest reverberation time which could be measured by a 2131/9825A system is in the region of 300 — 500 ms. The dynamic range of the measurement is to a certain extent

a function of the spectral shape of the sound field and the background noise, but it normally falls within the range of 30 — 40 dB.

Restrictions on the amount of memory space available in the 9825A for the storage of spectra might cause problems when there is a large spread between the reverberation times measured at high and low frequencies. The read-in time interval required to give sufficient accuracy at the high frequency end of the spectrum where the reverberation time could be low, may mean that the 9825A memory is filled before the low frequency decays are completed. However, the figure of 70 spectra for a 24 K 9825A given earlier assumes that a 1/3 octave spectrum from 1,6 Hz to 20 kHz is stored. If, for instance, only the channels from 100 Hz to 20 kHz are stored, the maximum number of spectra which can be input increases by a factor of 2.

In Table 1 are given some results obtained when the classical method of reverberation time measurement was compared with the method just described. They were obtained by tape recording a sufficiently large

1. Measurement using the classical method

	Octave Centre Frequency Hz							
	63	125	250	500	1 k	2 k	4 k	8 k
Mean reverberation time measured, s	5,00	3,48	1,64	1,51	1,59	1,44	1,29	1,01
Standard deviation, s	0,77	0,32	0,13	0,10	0,06	0,05	0,07	0,07

2. Measurement using 2131/7504

	Octave Centre Frequency Hz							
	63	125	250	500	1 k	2 k	4 k	8 k
Mean reverberation time measured, s	5,76	3,63	1,63	1,51	1,59	1,43	1,30	1,05
Standard deviation, s	1,59	0,76	0,16	0,18	0,17	0,11	0,12	0,14

Table 1

number of examples of the reverberation decay of a medium sized room. 10 of these decays were then measured using the classical method, utilizing a Band Pass Filter Set Type 1618, a Measuring Amplifier Type 2606, and a Level Recorder Type 2307. 30 of them were measured using the 2131 and a calculator, with a read-in interval of 100 ms. Both sets of results were subjected to a statistical analysis, the results of which can be found in Table 1. The results are quoted to two decimal places to show the excellence of the agreement between the two methods.

A fully automated system

The system described in the previous section demonstrates the feasibility of the use of a 2131 and a calculator to measure reverberation times, and can be further improved to make it fully automatic, overcoming two serious drawbacks, which are:

- i) The start of the read-in of spectra from the 2131 to the calculator and the switching off of the noise generator must both be manually operated.
- ii) The calculation of the reverberation time assumes a straight line decay. Decays with multiple slopes cannot be accommodated.

It is possible, to develop a system allowing for fully automated operation, with the 2131 and a Noise Generator Type 1405 being controlled over the IEC interface by a calculator such as the 9825A. Such a system is illustrated in Fig.2.

In this system, the 2131 transmits spectra to the 9825A at selected read-in intervals down to 44 ms, as before. The fundamental difference, however, is that the switching on and off of the noise generator is controlled by the 9825A. Although the 1405 does not have an IEC interface, it is still possible for the 9825A to have a limited degree of control over it. Of particular importance is that the 1405 Generator Stop can be remotely controlled. If the pins of the 1405 Remote Control Socket corresponding to this function are connected to the REN, (Remote Enable), lines of the IEC interface bus, then the 9825A can switch the noise output of the generator on and off at will by lowering and raising the REN line. Further, since the 2131 IEC interface does not use REN, the 2131 performance is unaffected. Note, however, that since REN is being used in a way not specified in the IEC standard, only the 2131 and 1405 should be connected to the 9825A.

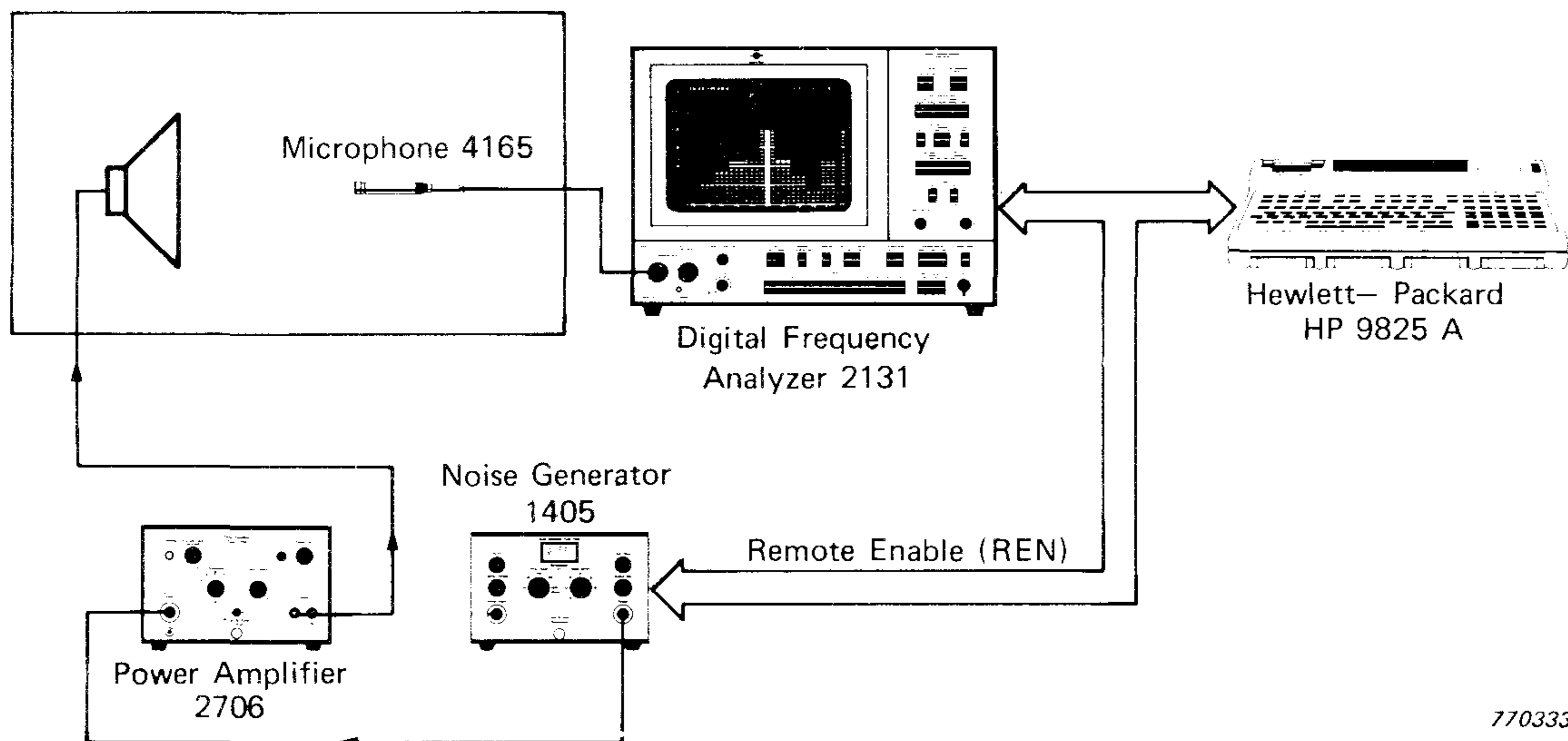

770333

Fig. 2. Automated system for reverberation time measurements

Automatic operation may now be obtained. Although it is still necessary to set the controls of the 1405 and its associated power amplifier manually, once these controls have been set, and the selected read-in interval has been entered, the system may be left to loop in an automatic cycle, where the 9825A switches off the noise generator, inputs the spectra from the 2131, calculates the reverberation times, and then switches the noise generator back on again to repeat the test a predetermined number of times. At the end of the operation, the average reverberation time in each channel, together with the standard deviation, can be printed out using a printer built into the 9825A.

Automatic operation of the system described above produces an extra bonus. This is that if the system is differently programmed, it becomes possible to accommodate a decay curve having multiple slopes. Previously, a linear decay had to be assumed, because the reverberation times were calculated individually for each decay, and the uncertainty in the points comprising the decay curves was too great to detect more than one slope. Further, any form of time domain averaging, other than increasing the averaging time setting on the 2131, was impossible, since the start of the read-in process was uncontrolled. However now, the read-in process can always be referenced to one fixed point, this being the switching off of the noise generator. Hence, from decay to decay, the spectra read from the 2131 to the 9825A may be read at precisely the same points in time with respect to the switching off of the noise generator.

The effect of the above is to allow the averaging process to be moved a stage earlier. Since the times at which the spectra were read in are now controlled, it becomes a valid process to average those spectra read in at the same time with respect to the switching off of the noise generator. For example, suppose 40 decays are measured with a read-in interval of 44 ms. Each spectrum making up the amplitude-frequency-time landscape would be an average of 40 spectra. Hence, if the first spectrum for each decay was read in 44 ms after the switching off of the noise generator, then the first spectrum of the landscape would be the average of 40 spectra all taken at 44 ms after switch off, the second spectrum would be the average of 40 spectra all taken at 88 ms, and so on. The landscape produced would in fact be the average of 40 landscapes, and the points making up the decay curves in each channel of the landscape would be very accurately defined. Hence, if the decay in each channel was displayed, the presence of two or more slopes could be detected, and the different reverberation times calculated.

Display of the decay curves would be possible using the display screen of the 2131 itself (see appendix where the program listing for 9825A is also included). Breaks in the curves could then be identified, and the points selected between which the reverberation time should be calculated, using the channel selector of the 2131 under the remote control of the 9825A. Finally, a hard copy of the results could be obtained using the printer in the 9825A.

Conclusion

It has been shown that the 2131, when used with a suitable desk-top calculator, is capable of making accurate measurements of reverberation time. Further, with programming, and the control of the Noise Generator Type 1405 over the IEC interface, a highly practical and sophisticated measurement system can be put together capable of making fast, accurate and automatic measurements. It is a system, however, which is not dedicated, and so with a change of programming, it can be used for other types of measurement. Alternatively, the individual instruments can be used on a stand alone basis.

APPENDIX

Some Practical Measurements

The following results were obtained using the system of Fig.1A. In this system, the Tektronix 4051 is used to enable examples of individual decay curves and three dimensional time-amplitude-frequency landscapes to be plotted. The decay is first entered into either buffer A or buffer B of the 4051 under control of the input routine. For these measurements, 50 spectra were input at intervals of 176 ms, (the minimum interval possible with the 4051), to give a total of 8,8 s of data. Since all of the measured reverberation times were under 3,5 seconds, this allowed a time interval of one or two seconds between the operator starting the input of spectra and switching off the noise generator.

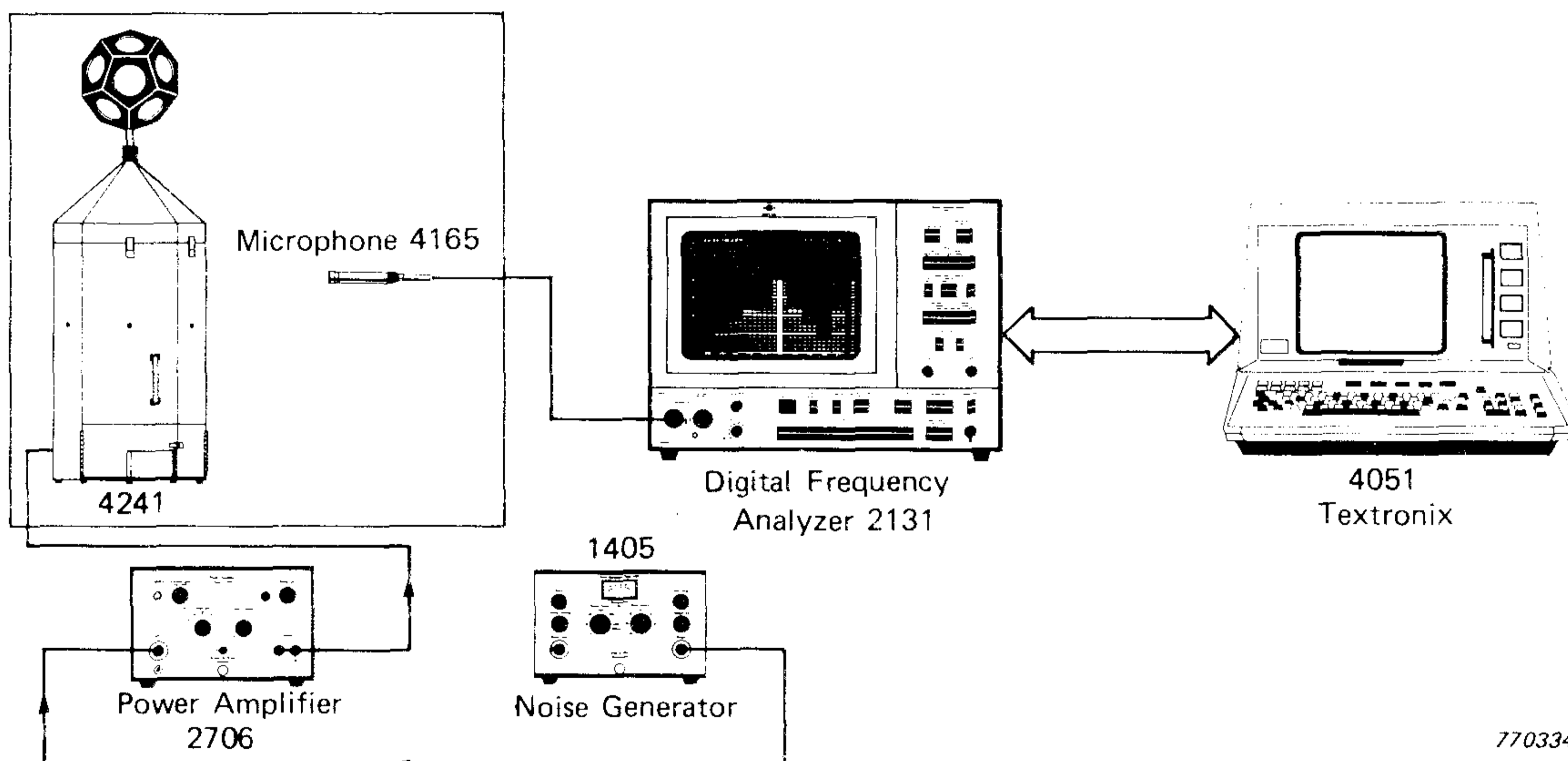

770334

Fig.1A. System used to obtain measurement results

The landscape for a single decay is shown in Fig.2A. For each channel of the landscape where sufficient data exists, a reverberation time can be calculated. The limits of the calculation, i.e. how far the decay should drop before the start of calculation, and how much further it should drop before the calculation stops, are entered via the calculator keyboard.

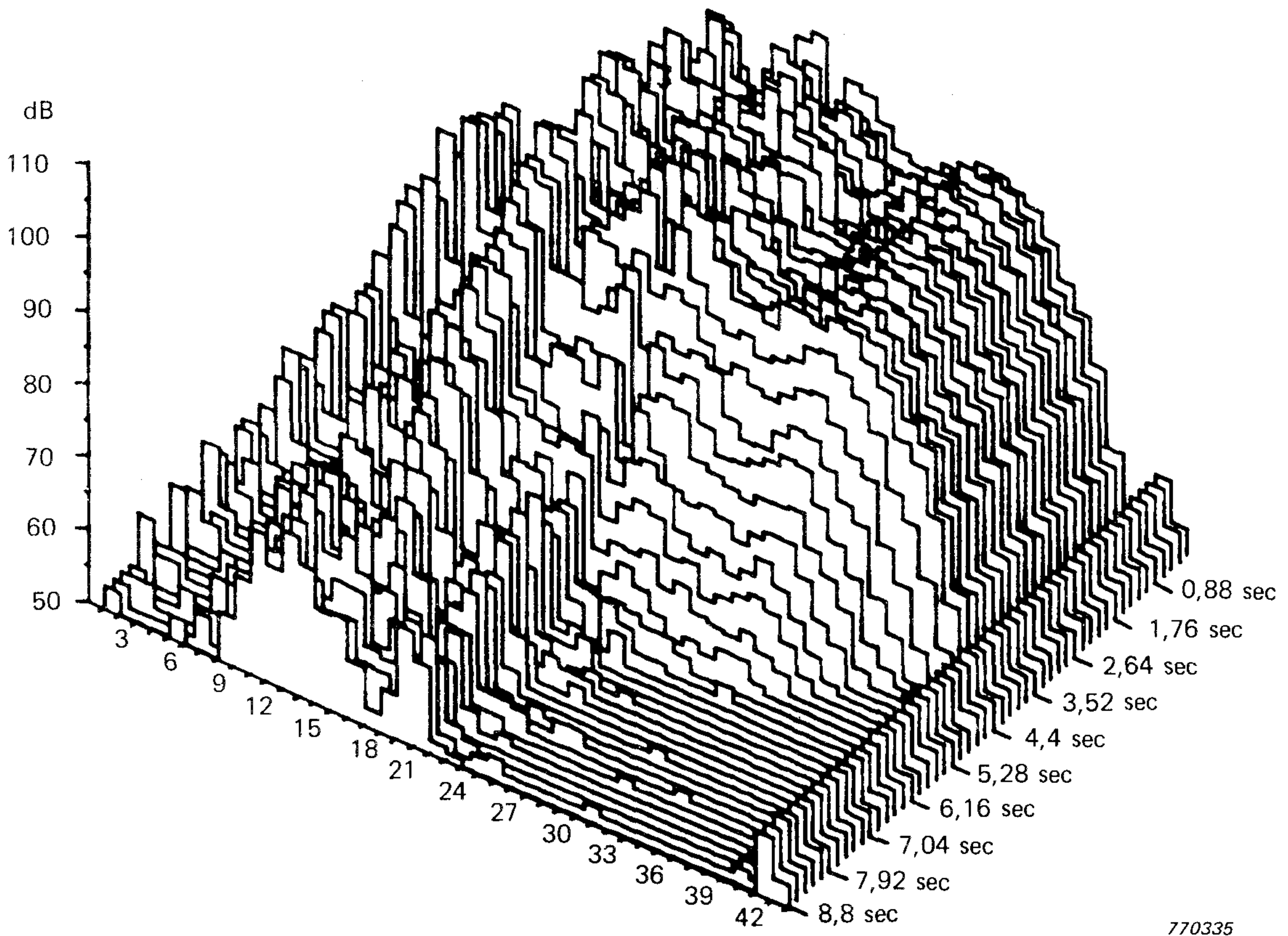

Fig.2A. Typical time-frequency-amplitude landscape

Fig.3A gives a bargraph showing the reverberation time calculated in each channel from 100 Hz to 20 kHz. A * in the channel indicates that there was insufficient information for the calculation.

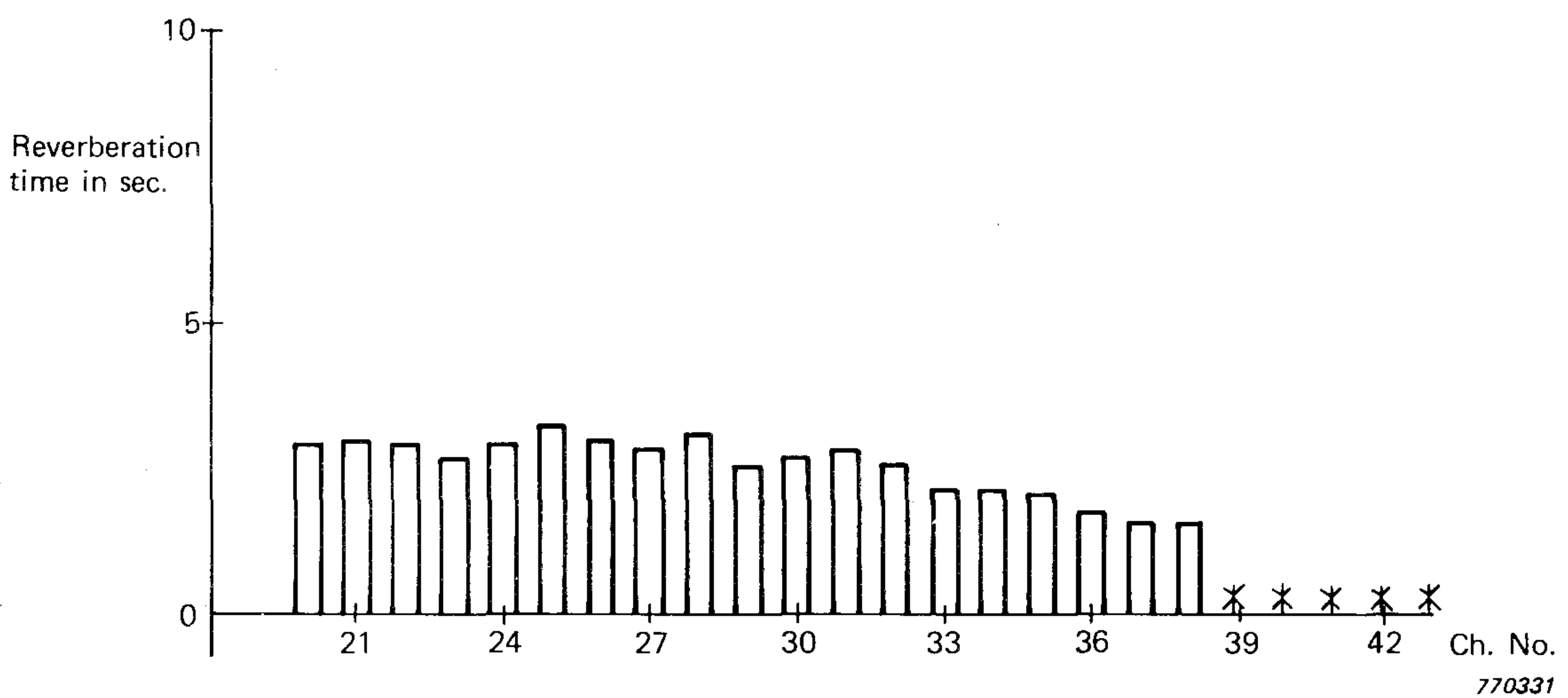

Fig.3A. Bargraph displaying reverberation time against channel number

Fig.4A shows typical decay curves, with the limits of calculation and the calculated slope displayed. The calculation assumes a straight line decay, and uses the method of least squares. It can be clearly seen from the curves how dynamic ranges of up to 40 dB can be expected, although here, a calculation interval of only 20 dB is used.

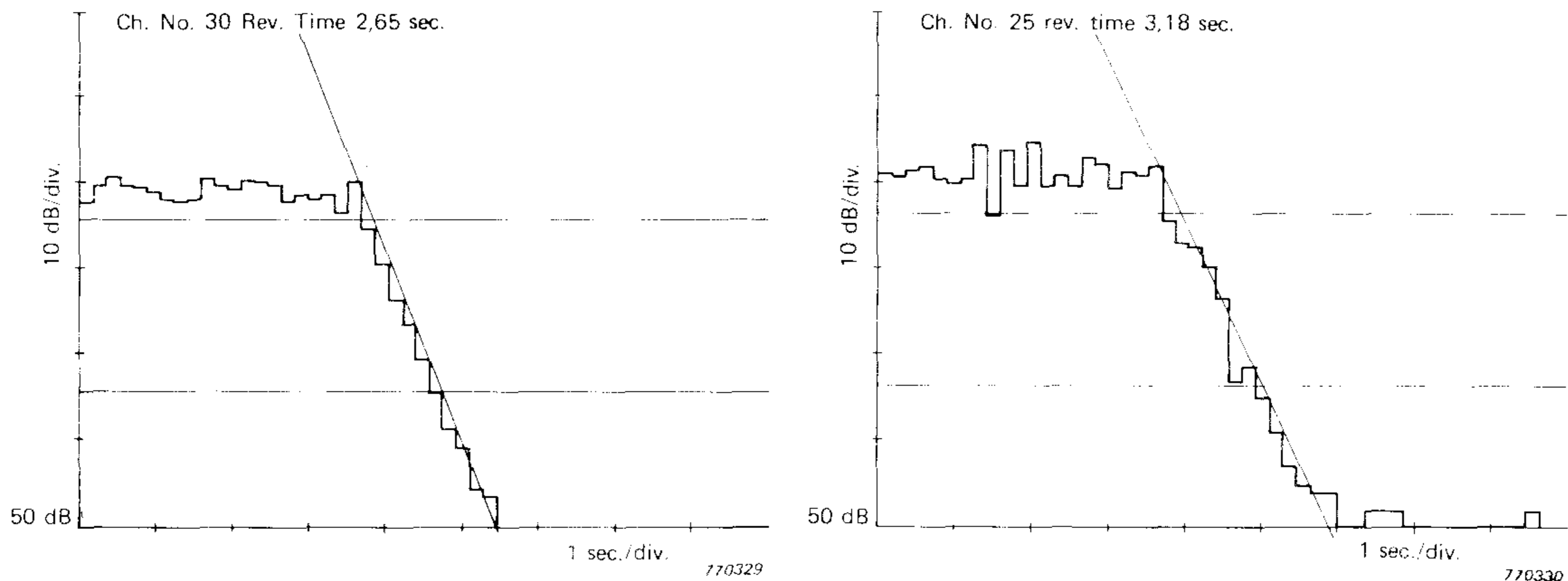

Fig.4A. Typical decay curves

The above measurements were for a single decay. In the fully automated system described earlier, a similar landscape to that of Fig.2A would be obtained, except that each point on the landscape would now become the average of many points. Hence, each point of the landscape would now become much more accurately defined. Also, the effects of background noise would be averaged out. In the calculation of the reverberation times following, this would not only allow the detection of multiple slopes, but would also maximize the dynamic range available for use in the calculation.

Description and Listing of the Program for the Hewlett-Packard Calculator 9825A for the fully automated method

The principle of operation is as follows: when the noise generator (controlled by the calculator) is switched off, the Digital Frequency Analyzer 2131 is instructed to transfer a predetermined number of spectra to the calculator with a prefixed time interval. These spectra are stored in the memory buffer where they are averaged with previously made recordings. The average spectra thus obtained are now integer-coded and held in another buffer in the memory. This procedure is repeated as many times as desired, after which the average spectra are stored on tape.

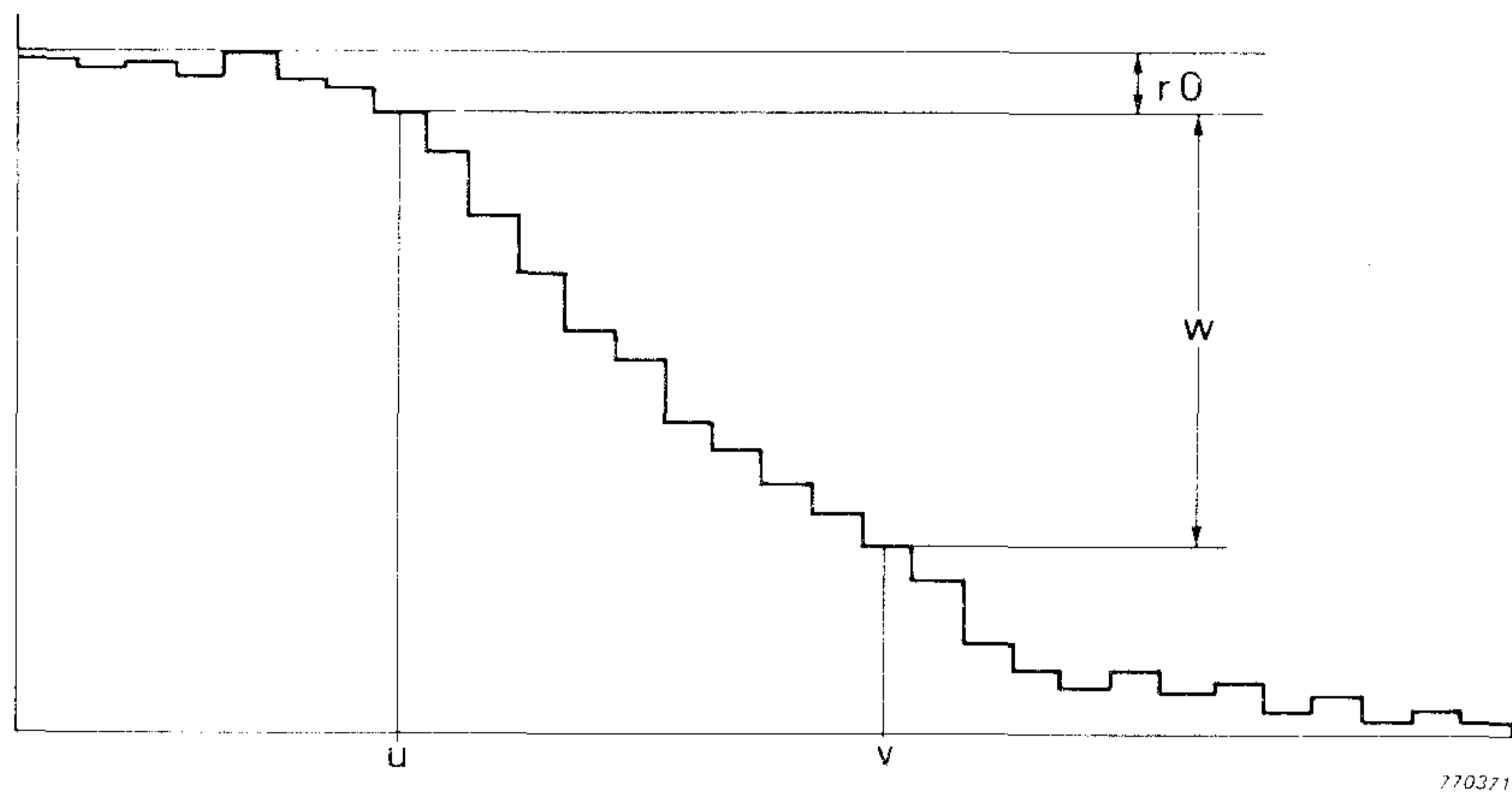

Fig.5A. Selection of limits for the line of best fit

A routine is then loaded which reloads the average spectra and displays the contents of any one of the $23 \frac{1}{3}$ octave filters between 63 Hz and 10 kHz against *time* on the screen of the 2131. After examining the contents in all the filters, any one frequency channel is chosen as reference, to select the limits between which the line of best fit is to be determined. With the aid of the channel selector the limits u and v are chosen (Fig.5A). The program now determines the line of best fit between the levels r_0 and $(r_0 + w)$ below the maximum level, in each frequency channel. (The line of best fit is determined using the method of least squares which minimizes the integral of the squared deviation between a straight line and the actual curve). From the slope of the curve the reverberation time is then determined.

STEP	DISPLAY	INSTRUCTIONS
1		Connect pins 1 and 2 on the 1405 remote control DIN-socket to lines 5 and 25 on the HP/IB (NOTE: NO OTHER INSTRUMENT USING THE REN LINE MUST BE CONNECTED TO THE HP/IB)
2		Turn power ON on all instruments
3	trk 1	Enter "trk 1 EXECUTE"
4	ldf 0	Enter "LOAD 0 EXECUTE"
5	*** Reverberation program ***	Press "RUN" 2131 is reset and 1405 started

STEP	DISPLAY	INSTRUCTIONS
6	Number of spectra pr. decay?	Enter the number of spectra pr. decay, min. 42 max. 65. If a value outside this range is entered the min. or max. value replaces the entered value
7	Sampling time (in ms)?	Enter the time interval between each spectrum to be sampled (min. 44 ms). The entered value is automatically rounded to nearest multiple of 21,96 ms (2131 cycle time). Averaging time on 2131 is set automatically
8		Data buffers are now being initialized and an interface check performed. If an error is found go to step 10. If not the next program part is loaded during step 9
9	Press f6 to stop sampling	In the following program section recording of reverb. decays is stopped (as soon as possible) and the calculation procedure loaded when f6 is pressed. Continue at step 11
10	** HP/IB or 2131 error **	A transmission error exists between the calculator and the 2131. Correct fault and press "RUN"
11	Recordings made: n	<p>The calculator is now recording reverberation decays. The time pr. recorded spectrum is approx. 1 sec (i.e. 65 sec for one decay resolved in 65 spectra). If sampling time or number of decays is inadequate press "STOP" and f0 to continue at step 6</p> <p>When sufficient recordings have been made press f6 and the last program part will be loaded and run as soon as possible. Obtained data are recorded on file 2 and 4</p>
12	** 2131 Calculator controlled **	The 2131 is now used as a display unit for the calculator and the 2131 should NOT be controlled via its front panel
13	Time Axis At: 63 Hz	The 2131 is displaying the contents of the bottom 1/3 octave filter used (centre frequency 63 Hz) with a time axis on the 2131. By pressing <input type="button" value="↑"/> or <input type="button" value="↓"/> the contents of the filter above or below the present is put on the screen. By pressing <input type="button" value="←"/> or <input type="button" value="→"/> the origin of the time axis is moved to the left or to the right
14		The interval in which a least squares fit is to be used is entered into the calculator by moving the 2131 channel selector (by means of buttons <input type="button" value="BACK"/> and <input type="button" value="FWD"/>) to the outer limits of the interval. The value is entered by pressing <input type="button" value="STORE"/> (only the last 2 entries are stored)
15	CH# 20 Reverb. time 0,9 s	When <input type="button" value="EXECUTE"/> is pressed calculation starts within the interval entered above. If calculation is impossible the calculator displays:

STEP	DISPLAY	INSTRUCTIONS
	CH# 29 Calculation impossible	
16	Reverb. times printed (Y)?	If "Y" is entered the calculated reverb. times are printed; return to step 12 afterwards. If only "CONTINUE" is pressed continue at step 12 without printing
17		If the contents of a channel are to be printed press "PRT ALL" and the channel on the 2131 screen is printed

TAPE ORGANIZATION :

```

Trkl/File #0 : DRIVER SECTION OF REVERB. PROGRAM Size : 1000 bytes
File #1 : SPECIAL FUNCTION KEYS Size : 500 bytes
File #2 : DATA BUFFER No. 1 Size : 100 bytes
File #3 : DATA ACQUISITION Size : 1000 bytes
File #4 : DATA BUFFER No. 2 Size : 5000 bytes
File #5 : DISPLAY AND CALC. OF REVERB. TIME Size : 5000 bytes
NO OTHER FILES USED

```

```

0: "B&K - Date : 77/05/03 - MS/1":
1: "DRIVER SECTION OF REVERBERATION PROGRAM":
2: dsp "**** Reverberation program ****"
3: cli 7;wait 1000;clr 7;wait 2000;trk 1;ldk 1;lcl 7
4: ent "Number of spectra pr. decay ?",N
5: if N>65;65→N
6: if N<42;42→N
7: ent "Sampling time (in ms) ? ",T
8: if T<43.92;44→T
9: 21.96int(T/21.96+.5)→T;0→C→R
10: dim A$(318),B$(161N),C$(46N),D$(1)
11: for I=1 to 46N by 2;fti (0)→C$(I);next I
12: buf "in",A$,3
13: dsp " Press f6 to stop sampling !";wait 1000
14: time 1000;on err "no2131"
15: wrt 717,"0";red 717,D$
16: char(46+int(log(T)/log(2)))→D$;.1*ln(10)→K
17: wrt 717,"M?K>F?D=I?M>M=O",D$
18: cfg ;trk 1;ldf 3,0
19: "no2131":for I=1 to 10;wait 500;dsp " "
20: wait 250;dsp "***** 2131 or HP/IB error *****";next I
21: end
*4080

```

```

f0 : *trkl;ldp0
f1 : *trkl;ldp5
f6 : *sfgl0
ALL OTHER SPECIAL FUNCTION KEYS EMPTY

```

```

0: "DATA ACQUISITION":
1: "1":if flgl0;gto "2"
2: wrt 717,"M?K>F?D=I?M>M=O",D$
3: for J=1 to N;wrt 717,"E?";tfr 716,"in",302
4: jmp rds("in")#-1
5: if J=5;rem 7
6: wrt 717,"E=";A$[120,278]→B$[159J-158,159J]
7: buf "in";wait T-43;next J;lcl 7
8: fxd 0;dsp "Number of recordings made :",C+1
9: for I=1 to N
10: for J=18 to 40;46I+2J-35→O
11: exp(Kval(B$[159I+7J-284,159I+7J-280]))→A
12: exp(.1Kitf(C$[O-46,O-45]))→B
13: fti (100log((A+CB)/(C+1)))→C$[O-46,O-45];next J
14: next I;C+1→C;gto "1"
15: "2":wrt 717,"N";red 717,D$;10(63-num(D$))→R;rem 7
16: trk 1;rcf 2,N,T,C,R;rcf 4,C$;ldp 5
17: end
*22835

```

```

0: "DISPLAY AND CALCULATION OF REVERB.TIME":
1: trk 1;ldf 2,N,T,C,B;T/1000→T
2: dim B[N],C$[46N],R$[46],X$[1]
3: ldf 4,C$
4: cli 7;wrt 717,"D=J?";cfg
5: "START":
6: dsp "** 2131 CALCULATOR CONTROLLED *";wait 1000
7: 6→V;5→U;1→P→Q→S;17→A→J;sfg 1;jmp 3
8: "KEYBOARD":
9: rdb(0)→A
10: if A=10;gto "REV.TIME"
11: if A=13;V→U;Q→V
12: if A=14;P-1→P;gto "PAGE?"
13: if A=15;P+1→P;gto "PAGE?"
14: if A=17;sfg 0;J+1→J;if J>40;40→J;cfg 0
15: if A=16;sfg 0;J-1→J;if J<18;18→J;cfg 0
16: if A=19;gto "CHECK"
17: if A=20;wrt 717,"E=D?E?";Q-1→Q;if Q<S;S→Q
18: if A=21;wrt 717,"E=D>E?";Q+1→Q;if Q>S+41;S+41→Q;wrt 717,"E=D?E?"
19: if flg0;gsb "DISPLAY"
20: gto "KEYBOARD"
21: "PAGE?":
22: if P>4;4→P;jmp 6
23: if P<1;1→P;jmp 5
24: if P<=2 and not flgl;cfg 2;sfg 1;1→S→Q;gsb "DISPLAY"
25: if P>2 and not flg2;N-41→S→Q;cfg 1;sfg 2;gsb "DISPLAY"
26: if P=1 or P=3;wrt 717,"J?"
27: if P=2 or P=4;wrt 717,"J>"
28: gto "KEYBOARD"
29: "DISPLAY":
30: cfg 0;gsb "UNP"
31: if P=1 or P=3;wrt 717,"E=J?F>"
32: if P=2 or P=4;wrt 717,"E=J>F>"
33: fmt 1,fz5.1;wrt 716.1,B
34: for I=S to S+41;wrt 716.1,B[I];next I
35: wrt 717,"F?E?";for I=S to Q-1;wrt 717,"E=D>E?";next I
36: fxd 0;dsp "TIMEAXIS AT :",drnd(10^(J/10),2)," Hz"
37: ret
38: "REV.TIME":
39: fxd 1;if V<U;V→X;U→V;X→U

```

```

40: max(B[*])→M;M-B[U]→r0;B[U]-B[V]→W
41: fmt 2,"CH# ",f3.0,"      Reverb.time",f4.1," s"
42: fmt 3,"CH# ",f3.0," Calculation impossible"
43: for J=18 to 40
44: gsb "UNP"
45: N→I;W→r2;0→r4→r5→L;max(B[*])→M
46: if B[I]<M-r0;I-1→I;if I>0;jmp 0
47: I+1→r1
48: if r1>=N;"**"→R$[O,O+1];gto "exit"
49: if B[r1]-r2-5<=B;r2/2→r2;if r2<1;jmp 0
50: if B[I]>=M-r0-r2;I+1→I;if I<N;jmp 0
51: I→r3
52: if r3>=N or r1>=r3;"**"→R$[O,O+1];gto "exit"
53: .5(r3-r1)T+r1T→r6
54: for I=r1 to r3;B[I]+L→L;r4+B[I]IT→r4;r5+IITT→r5;next I
55: (r4-Lr6)/(r5-(r3-r1+1)r6r6)→r7
56: if r7>=-.00001;"**"→R$[O,O+1];gto "exit"
57: -60/r7→R;fti (10R)→R$[O,O+1]
58: "exit":if R$[O,O+1]="**";wrt .3,J;jmp 2
59: wrt .2,J,R
60: next J
61: wait 1000;ent "REVERB.TIMES PRINTED ? Y(es)",X$
62: if flgl3;gto "START"
63: gto "PRI"
64: "UNP":
65: 2(J-18)+1→O
66: for I=1 to N;itf(C$[O+46(I-1)])/10→B[I];next I
67: ret
68: "PRI":
69: fxd 0;prt "Number or recor-";prt "dings:",C;spc
70: prt "Reverberation -      time in s"
71: prt "-----"
72: fmt 4,"Ch# ",f2.0,x,f5.1," s  "
73: fmt 5,"Ch# ",f2.0,2x,"***",4x
74: for I=18 to 40;2(I-18)+1→O
75: if R$[O,O+1]="**";wrt 16.5,I;jmp 2
76: wrt 16.4,I,itf(R$[O,O+1])/10
77: next I;spc
78: prt "* stars indicatethat calculationhas been impos- sible."
79: spc 2;gto "START"
80: "CHECK":
81: fxd 0;prt "Level against      time in ch#",J;prt "-----"
82: fmt 6,f6.3," s ",f5.1
83: for I=1 to N;wrt 16.6,I*T,B[I];next I
84: spc 2;gto "KEYBOARD"
85: "end":end
*26916

```

Measurement of Elastic Modulus and Loss Factor of PVC at High Frequencies

by

O. B. Sørensen and V. Tarnow

ABSTRACT

In this article a method is described for determining the elastic modulus and loss factor of PVC in the frequency range 10 — 90 kHz by exciting the longitudinal modes of vibration of the specimens. Piezoelectric crystals are used as the transmitting and receiving transducers, whereby resonance problems normally encountered in conventional transducers in this frequency range are avoided.

SOMMAIRE

Cet article décrit une méthode permettant de déterminer le module d'élasticité et le facteur de perte du PVC sur la gamme de fréquence 10 — 90 kHz en excitant les modes vibratoires longitudinaux des spécimens. On utilise des cristaux piézoélectriques comme transducteurs émetteurs et récepteurs, ce qui élimine les problèmes de résonance normalement rencontrés avec les transducteurs classiques sur cette gamme de fréquence.

ZUSAMMENFASSUNG

In diesem Artikel wird eine Methode zur Ermittlung des E-Moduls und des Verlustfaktors von PVC im Frequenzbereich von 10 — 90 kHz beschrieben. Es werden die longitudinalen Schwingungen in der Probe angeregt. Als Sender und Empfänger werden piezoelektrische Kristalle verwendet, wodurch Resonanzprobleme, wie sie bei anderen Wandlern in diesem Frequenzbereich auftreten, vermieden werden.

Introduction

Production of gramophone records with signal frequencies up to 45 kHz has created an interest in the determination of elastic modulus and loss factor of PVC at high frequencies. Conventional methods of elastic mod-

ulus measurement have made use of transverse vibration excitation of PVC bars, and reasonably accurate results have been obtained up to 10 kHz. At higher frequencies, however, the method becomes impractical on account of transducer resonances, and the complex vibration modes of the specimen. In this article a method is described for longitudinal excitation of PVC samples, where piezoelectric crystals are used as the excitation and receiving transducers.

Measurement Method

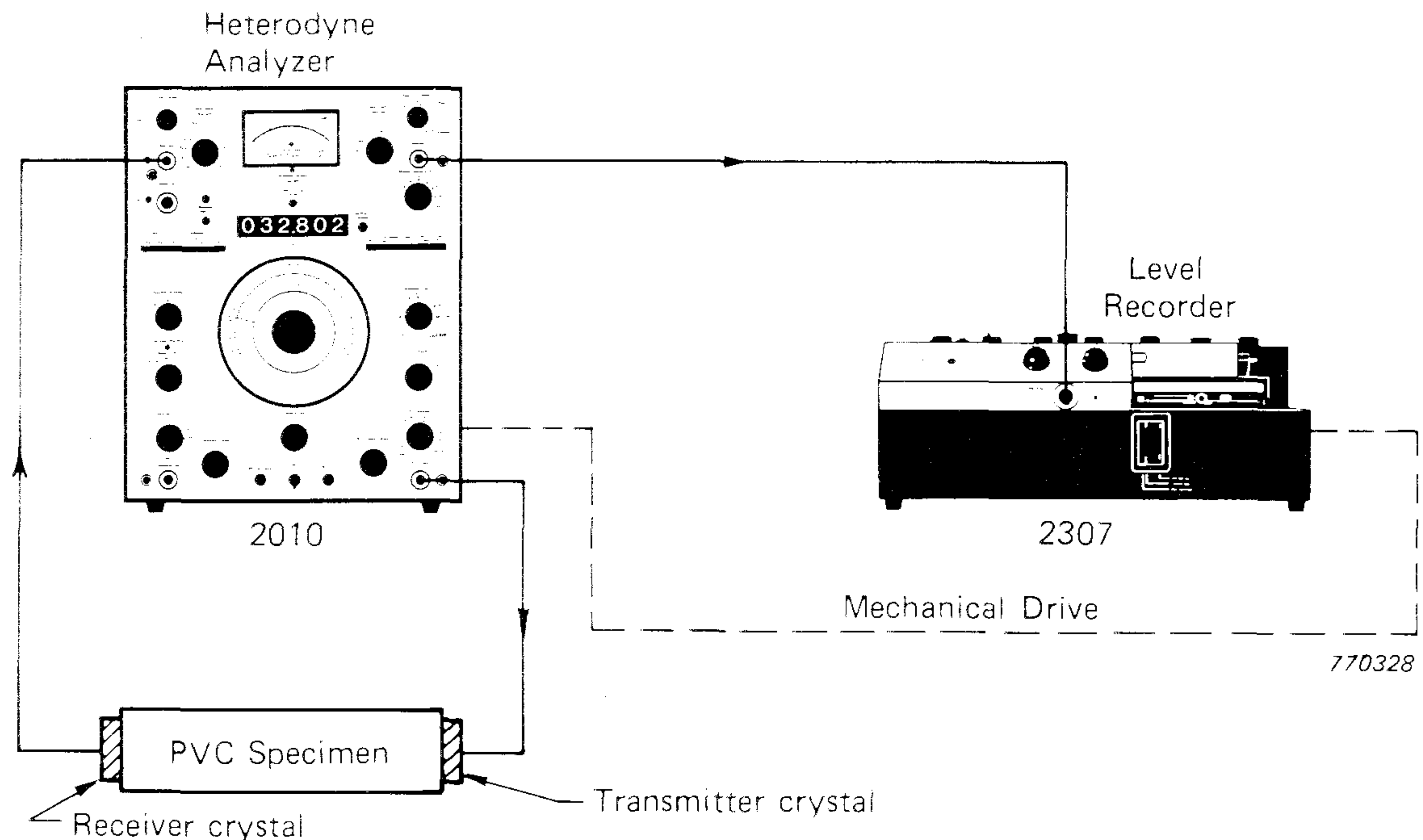

Fig.1. Measuring Arrangement

Fig.1 shows a measurement set-up for the longitudinal excitation of a PVC bar of cross section $8,2 \times 8,2$ mm. At both ends of the specimen silver-plated piezoelectric crystals (leadzirconiumtitanate) are attached with the aid of PVC screws, Fig.2. Excitation voltage to the transmitting crystal is supplied by the B.F.O. section of the Heterodyne Analyzer Type 2010, while the signal picked up by the receiving crystal is fed to the Level Recorder Type 2307 via the analyzer section of 2010. The frequency of the analyzer is scanned from 10 kHz upwards so that the longitudinal vibration modes of the specimen are excited.

Fig.3 shows responses of four PVC bars of lengths 15, 25, 30 and 50 mm. The longitudinal resonant frequencies of the specimens depend on the specimen length, elastic modulus, density of the material and the mass of the transmitting and receiving piezoelectric crystals and

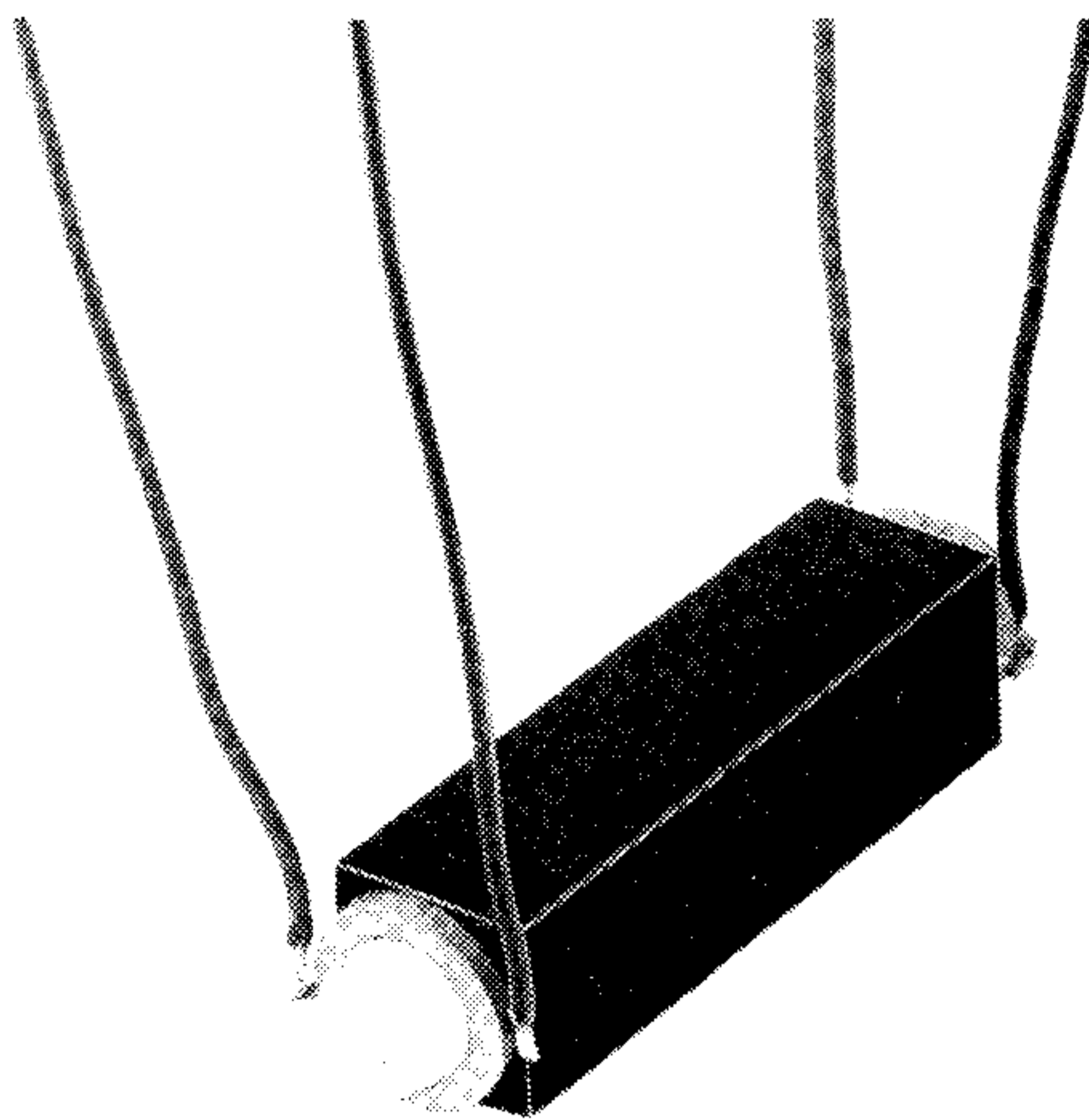

Fig.2. PVC sample with piezoelectric crystals

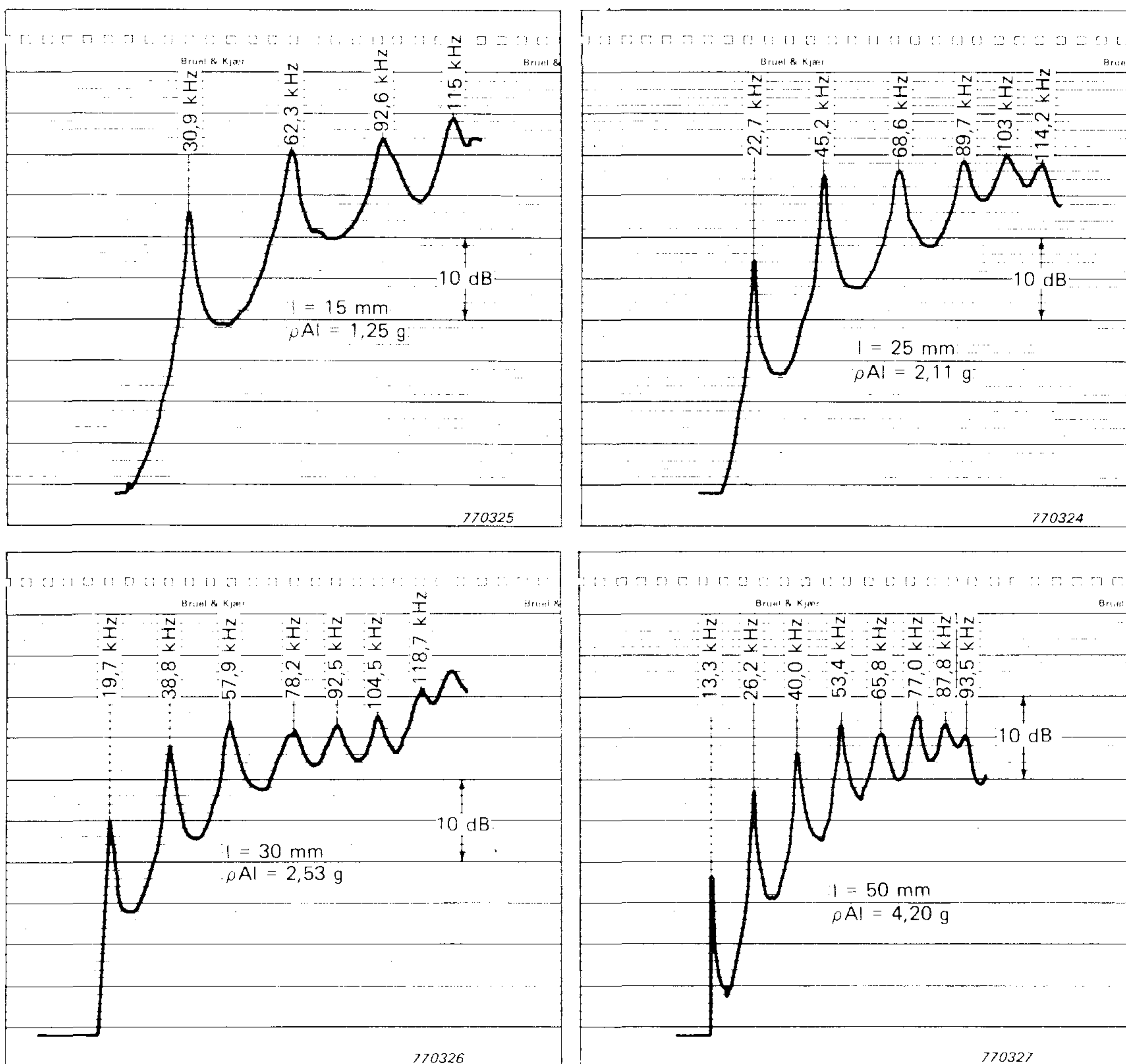

Fig.3. Frequency Response of PVC samples

screws. The resonant frequencies and the —3 dB bandwidths can be determined accurately, using the built-in digital frequency display of the Heterodyne Analyzer.

Using Rayleigh's principle the longitudinal resonant frequencies of the specimen can be related to the elastic modulus (see Appendix) by the formula

$$f_n = \frac{\frac{n}{2l} \sqrt{\frac{E}{\rho}}}{\sqrt{1 + \frac{4m}{M}}}$$

where l is the length of the specimen (m)
 E is the elastic modulus of the material (N/m^2)
 ρ is the density of the material (kg/m^3)
 m is the mass of each piezoelectric crystal and screw (kg)
 M is the mass of the specimen (kg)
and n is the mode number.

The Loss Factor η is given by

$$\eta = \frac{\Delta f}{f_n}$$

where Δf is the —3 dB bandwidth

and f_n is the resonant frequency of the n^{th} mode.

The resonant frequencies measured are plotted against the mode number in Fig.4 for the four specimens. The linear relationship can be seen

to be valid up to approximately 90 kHz, indicating that the sound velocity ($c = \sqrt{E/\rho}$) is constant in the material. The method, however, is limited at higher frequencies as the cross-sectional dimensions of the specimen become comparable to half the wavelength of the excitation frequency. The vibration modes also become complicated and the end fixing conditions influence the results.

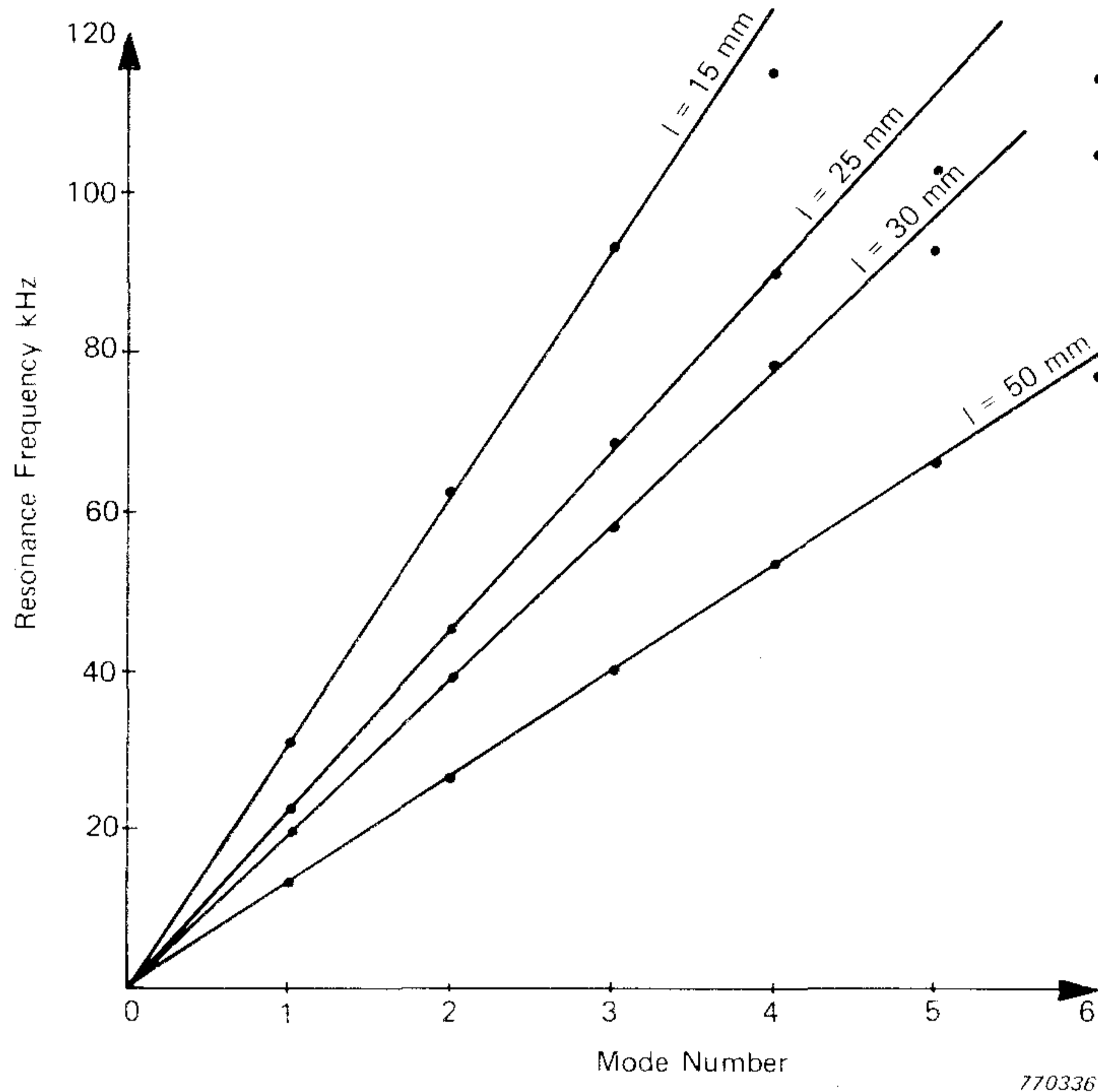

Fig.4. Resonance Frequencies versus mode number

When determining the loss factor η , it was found that more consistent results were obtained when the piezoelectric crystals were glued onto the specimens than when they were screwed on. This was most likely because of friction between the screw threads and the specimen.

The elastic modulus and loss factor evaluated from the above equations are given in Table 1, while Fig.5 shows the spread in the results around the mean value.

Conclusion

A simple method has been outlined for the determination of elastic modulus and loss factor of PVC at high frequencies. The results are found to be reasonably consistent in the frequency range investigated. By changing the dimensions of the specimen, results can be obtained at other frequencies than those considered here.

	$f_{n=1}$	$f_{n=2}$	$f_{n=3}$	$f_{n=4}$	$f_{n=5}$	$f_{n=6}$
$E_{l=15} \times 10^9 \text{ N/m}^2$	2,96	3,00	2,95	2,56		
$E_{l=25} \times 10^9 \text{ N/m}^2$ η	3,24 0,048	3,21 0,042	3,26 0,049	3,16		
$E_{l=30} \times 10^9 \text{ N/m}^2$	3,51	3,40	3,37	3,46	3,10	2,75
$E_{l=50} \times 10^9 \text{ N/m}^2$ η	3,40 0,046	3,30 0,043	3,42 0,049	3,43 0,042	3,33 0,042	3,17 0,047

Table 1

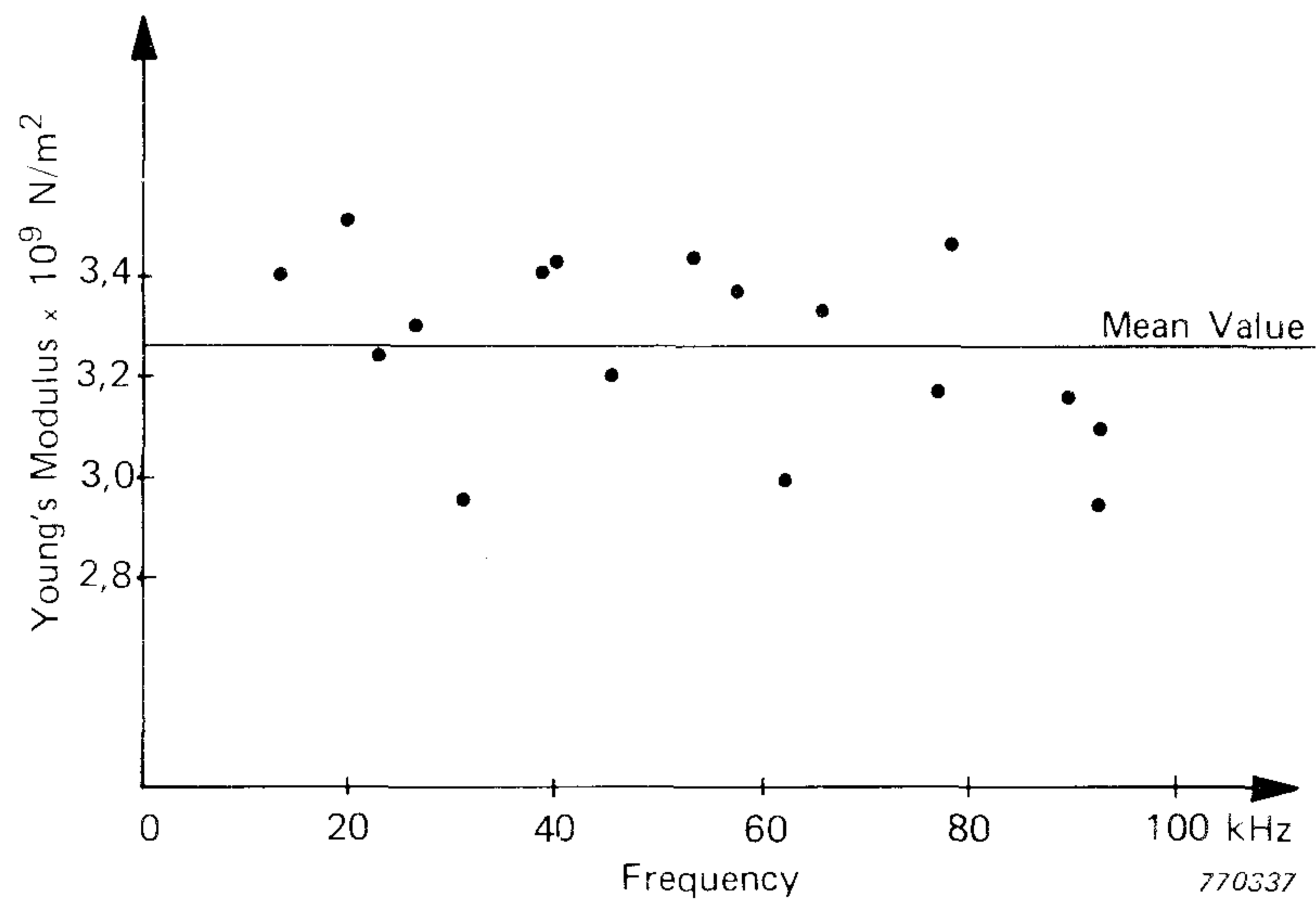
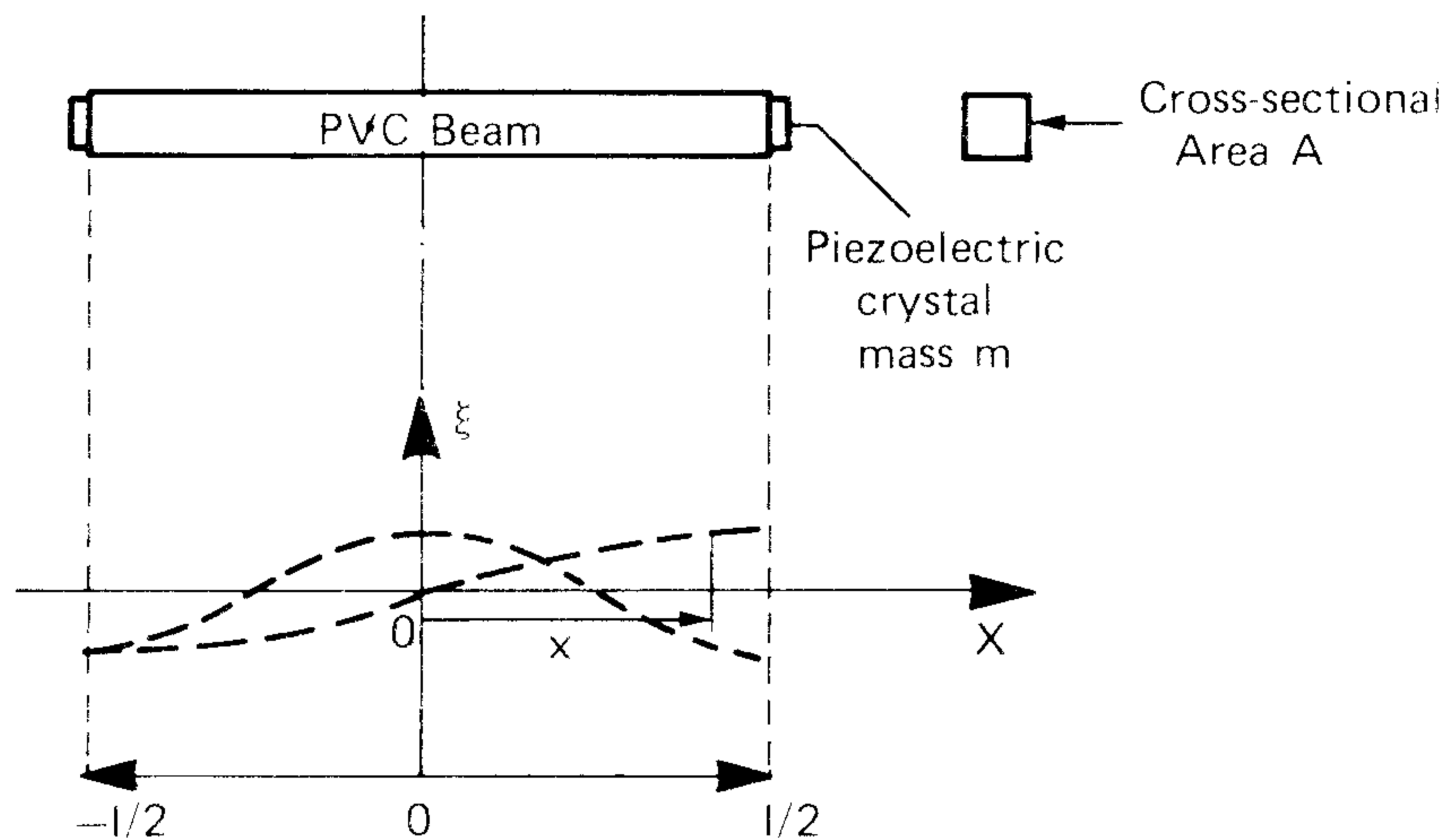

Fig.5. Spread in the values of elastic modulus

APPENDIX



770370

Fig.1A. Free-free uniform beam

Fig.1A shows a uniform free-free beam and the dotted lines show its assumed normal modes of longitudinal vibration. Consider an element at a distance x from the origin. ξ represents the displacement of the element *along* the X axis and is given by

$$\xi = \xi_0 \begin{cases} \sin\left(\frac{n\pi x}{l}\right) & \text{for } n \text{ odd} \\ \cos\left(\frac{n\pi x}{l}\right) & \text{for } n \text{ even} \end{cases}$$

The strain at the element is given by

$$\frac{d\xi}{dx} = \xi_0 \frac{n\pi}{l} \cos\left(\frac{n\pi x}{l}\right) \quad \text{for } n \text{ odd}$$

The potential energy can now be calculated from

$$E_{\text{Pot}} = A \int_{-\frac{l}{2}}^{\frac{l}{2}} \frac{1}{2} E \left(\frac{d\xi}{dx} \right)^2 dx$$

where E is the Young's Modulus
and A is the cross-sectional area

Substituting and integrating we get

$$E_{\text{Pot}} = \frac{1}{4} AEI \xi_0^2 n^2 \left(\frac{\pi}{l} \right)^2$$

The velocity of the element is given by

$$\dot{\xi} = \omega \xi_0 \sin\left(\frac{n\pi x}{l}\right)$$

The kinetic energy can now be calculated from

$$E_{\text{Kin}} = A \int_{-\frac{l}{2}}^{\frac{l}{2}} \frac{1}{2} \rho \dot{\xi}^2 dx + 2 \times \frac{1}{2} m \dot{\xi}_{x=l/2}^2$$

where ρ is the density of the beam material
and m is the mass of each piezoelectric crystal and screw

Substituting we get

$$E_{\text{Kin}} = \frac{1}{2} A\rho \int_{-\frac{l}{2}}^{\frac{l}{2}} \omega^2 \xi_0^2 \sin^2\left(\frac{n\pi x}{l}\right) dx + m \omega^2 \xi_0^2$$

$$\text{i.e. } E_{\text{Kin}} = \xi_0^2 \omega^2 \left(\frac{1}{4} \rho Al + m \right)$$

Using Rayleigh's Principle, for a conservative system at resonance maximum potential energy equals maximum kinetic energy

$$\text{i.e. } \frac{1}{4} AE l \xi_0^2 n^2 \left(\frac{\pi}{l}\right)^2 = \xi_0^2 \omega_n^2 \left(\frac{1}{4} \rho Al + m\right)$$

$$\omega_n^2 = \frac{n^2 \frac{E}{\rho} \left(\frac{\pi}{l}\right)^2}{1 + \frac{4m}{\rho Al}}$$

$$\text{i.e. } f_n = \frac{\frac{n}{2l} \sqrt{\frac{E}{\rho}}}{\sqrt{1 + \frac{4m}{M}}} \quad \text{where } M \text{ is the total mass of the beam.}$$

NOTE: The same result would have been obtained if the expression for displacement $\xi = \cos(n\pi x/l)$ for n even had been used instead of for n odd.

News from the Factory

Tracking Filter Type 1623

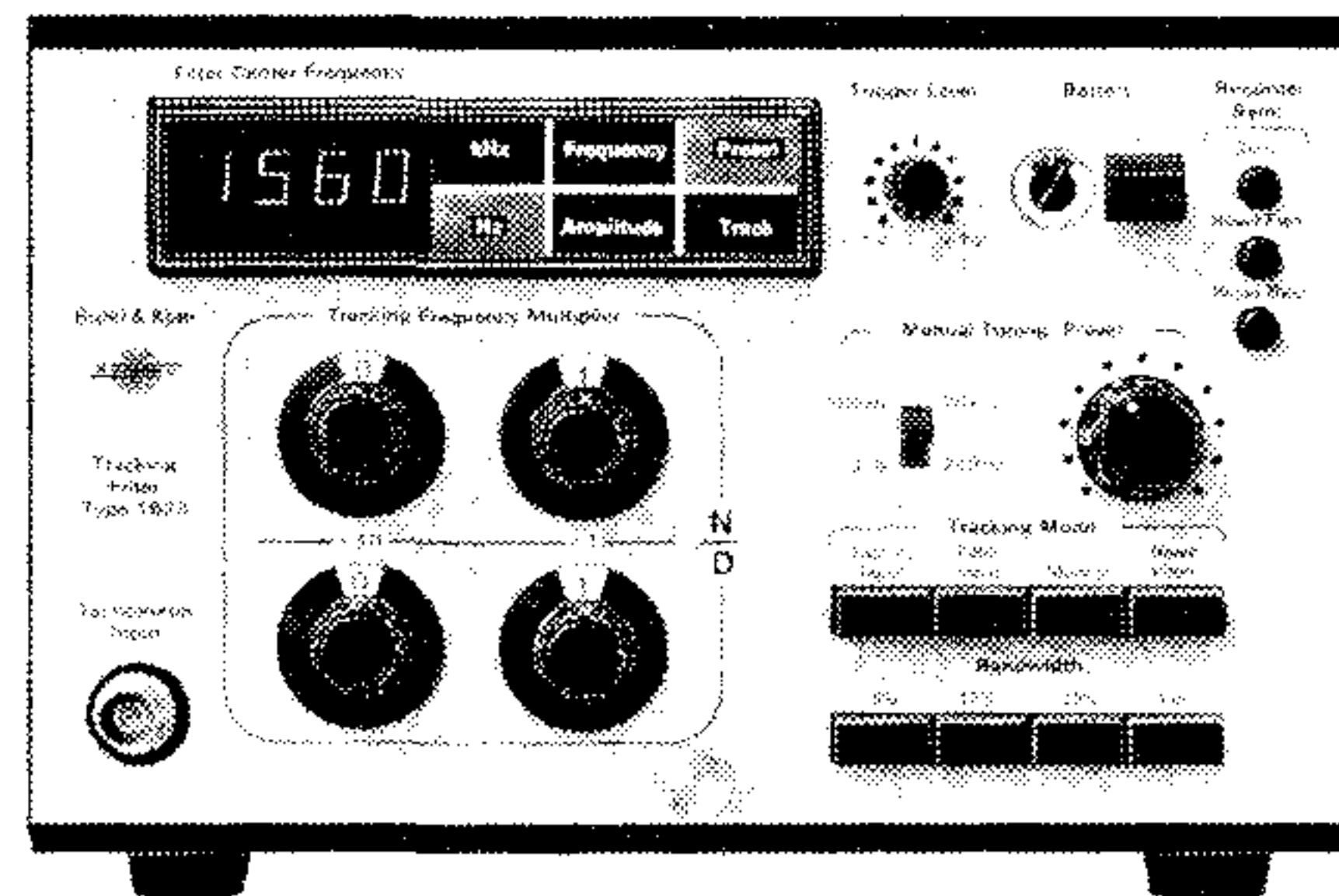

When examining the vibration spectra during machinery run-up or spectra of variable speed machinery, a filter which can be synchronized with the rotation speed is often desired. The Tracking Filter Type 1623 provides this facility and can be used for many synchronous and harmonic measurements on vibration and electroacoustic signals.

The 1623 is a narrow bandwidth filter whose frequency automatically locks onto and follows the fundamental frequency, or any ratio thereof between $1/99$ and $99/1$, of a periodic tuning signal. With rotating machinery the tuning signal can be provided, for example, by a Photoelectric Tachometer Probe MM 0012 or a Magnetic Transducer MM 0002. The filter when combined with the General Purpose Vibration Meter Type 2511 makes a versatile portable battery operated vibration analyzer ideal for field operation. Because the filter can alternatively be tuned manually over its full frequency range of 2 Hz to 20 kHz the combination can also be used as an ordinary non-synchronous vibration analyzer.

The filter which has a dynamic range of about 70 dB consists of a digitally tuned pair of two-pole Butterworth filters. The effective noise band-

widths are 6%, 12%, and 23% (1/3 octave) and are selected by push buttons. Synchronizing signals are also provided for the Level Recorder Type 2306 and an X—Y recorder.

Portable Oscilloscope Type 4714

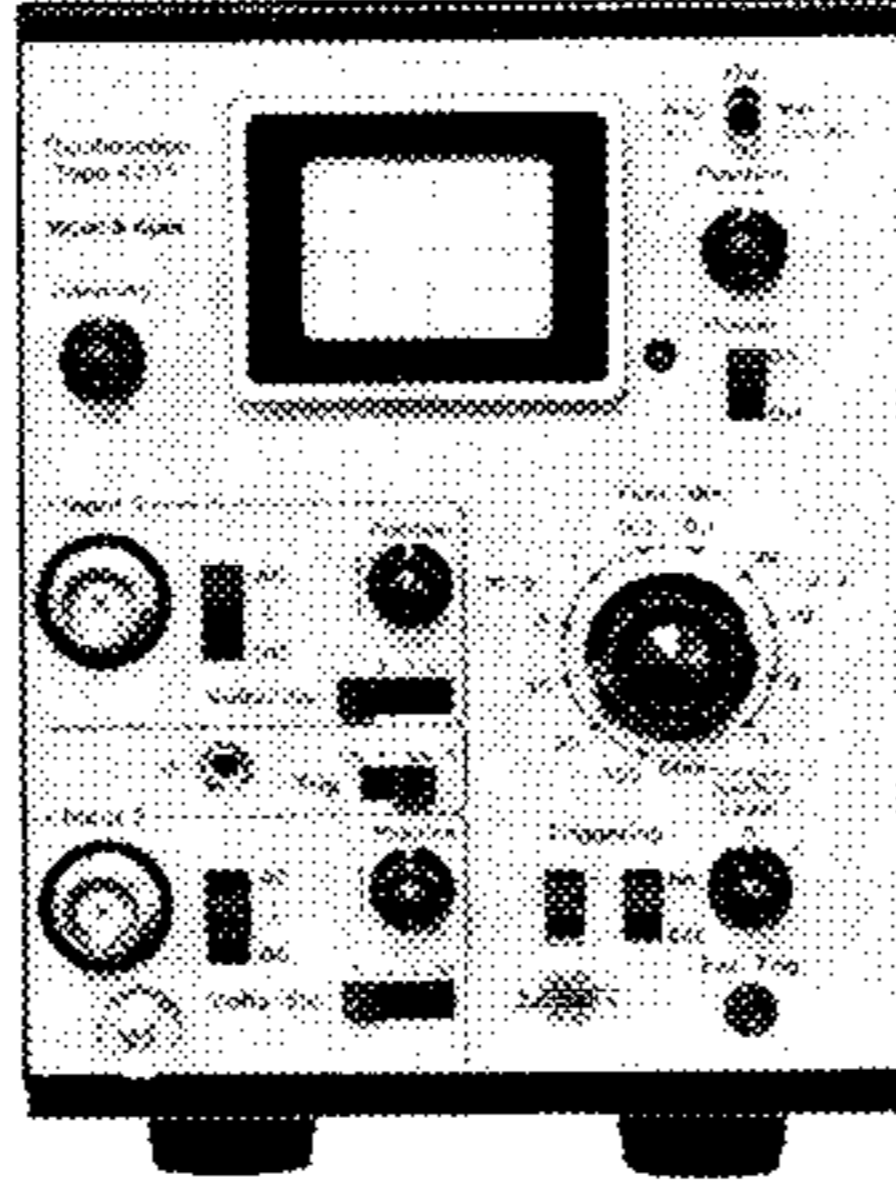

The 4714 is a small lightweight, portable oscilloscope with measurement capability and performance comparable with laboratory oscilloscopes many times its size. Dual trace and a wide measurement bandwidth from DC up to 5 MHz are but two of its features that permit the display of a wide variety of analogue and digital signals on a miniature CRT display. The display has a 4 by 6 division graticule mounted flush with its screen for parallex free viewing and is provided with a slip-on lens which magnifies the display approximately 1,5 times.

The two channels of the oscilloscope may be "AC" or "DC" coupled and have separate BNC inputs with high input impedance, dual FET amplifier stages for low sensitivity to temperature and line voltage changes. Calibrated sensitivity settings of 0,03, 0,1, 0,3, and 1 V/division may be selected which, with the 10:1 oscilloscope probe permit input voltages up to $400 V_{p-p}$ to be displayed.

Calibrated sweep speeds from 100 ms to $0,3 \mu s$ may be selected using a 10-position switch enabling long as well as short duration signals with repetition times from 0,5 s to 100 ns to be displayed. Fast rise time pulses and shocks can be expanded using a $MAG \times 10$ switch situated beside the CRT display. For triggering the oscilloscope either Automatic or Normal trigger mode may be selected.

Power may be provided using an AC Mains Adaptor or battery. Both are supplied as standard accessories with the oscilloscope and either of them may be plugged into the supply compartment at the rear of the oscilloscope.

Alphanumeric Printer Type 2312

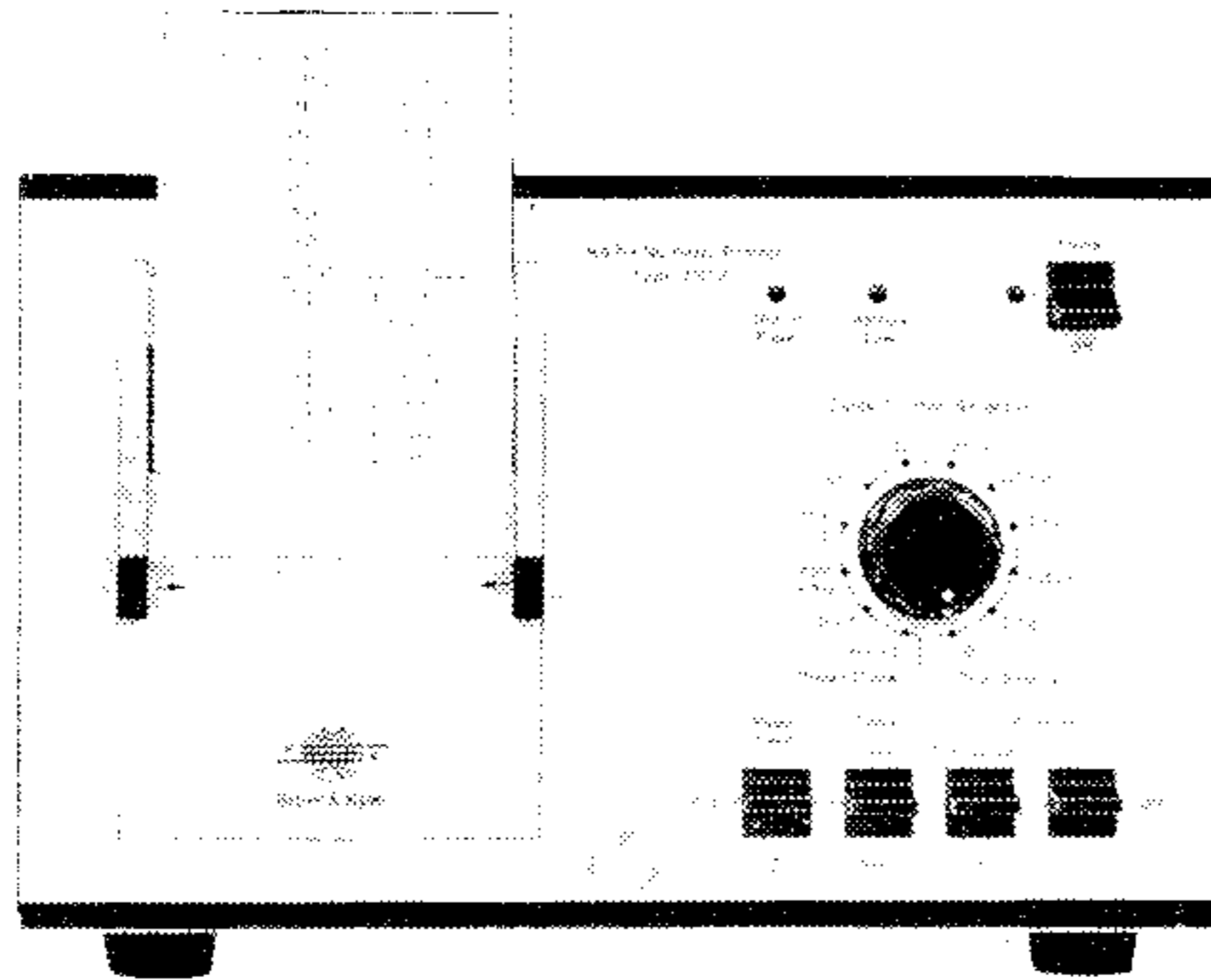

The Alphanumeric Printer Type 2312 accepts ASCII coded data, resolves them into as many as 64 alphanumeric characters and quietly prints them on a roll of heat sensitive paper at rates up to 24 characters/s. It functions as an output section to give a hard copy of results of measurements made with instruments that have an ASCII coded digital output such as the Noise Level Analyzer Type 4426, Strain Measurement System Type 1526/1544/1545, and the Digital Frequency Analyzer Type 2131.

All internal time sequences are regulated by means of a built-in crystal clock generator that has an overall accuracy better than ± 2 minutes per month in the temperature range -10° to $+50^{\circ}\text{C}$. The internal clock can be used to start an automatic print-out of data at pre-selected intervals, in steps from 10 s to 60 minutes. When time intervals other than those provided by the instrument settings are required, the printer can be externally controlled by the transmitter or by an external clock circuit. The clock measures in days, hours and minutes, which are recorded at the head of each data file to establish the time of origin for identification purposes.

For field use the Printer can be powered either by $6 \times 1,5\text{ V}$ batteries or by $6 \times 1,2\text{ V}$ NiCd rechargeable cells. Alternatively, Power Supply Type 2808 can be used for on line voltages between 100 and 240V or an external 12 V DC supply, for example the ZG 0113.

For long term applications a selector switch enables a "Low Power" mode to be chosen (only when operating with B & K interface) so that the standby current demand is reduced, giving a lifetime of approximately 5 weeks on fully charged NiCd cells.

When the battery power is not sufficient to drive the Printer, the "Battery Low" lamp blinks and the print out is inhibited until the cells have been replaced or recharged.

Accelerometer Type 4371

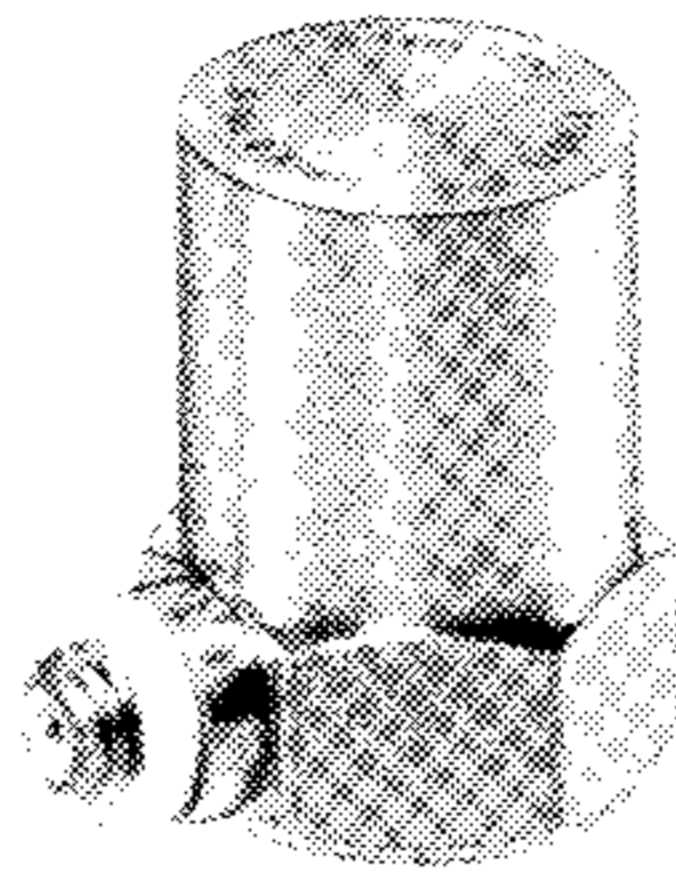

To take advantage of the new Delta Shear[®] design, the unigain general purpose accelerometers are replaced by Type 4371 having a charge sensitivity of $1 \text{ pC/ms}^{-2} \pm 2\%$. On account of the new design the sensitivity of the accelerometer to base strains and temperature transients is significantly reduced. The accelerometer is optimized to have good all-round specifications making it suitable for applications in industry, laboratory and in education.

PREVIOUSLY ISSUED NUMBERS OF BRÜEL & KJÆR TECHNICAL REVIEW

(Continued from cover page 2)

- 1-1974 Measurements of averaging times of Level Recorders Types 2305 and 2307.
A simple Equipment for direct Measurement of Reverberation Time using Level Recorder Type 2305.
Influence of Sunbeams striking the Diaphragms of Measuring Microphones.
- 4-1973 Laboratory tests of the Dynamic Performance of a Turbocharger Rotor-Bearing System.
Measurements on the Resonance Frequencies of a Turbocharger Rotor.
- 3-1973 Sources of Error in Noise Dose Measurements.
Infrasonic Measurements.
Determination of Resonance Frequencies of Blades and Disc of a Compressor Impeller.
- 2-1973 High Speed Narrow Band Analysis using the Digital Event Recorder Type 7502.
Calibration Problems in Bone Vibration with reference to IEC R 373 and ANSI S3. 13-1972.
An Investigation of the Near Field Screen Efficiency for Noise Attenuation.

SPECIAL TECHNICAL LITERATURE

As shown on the back cover page Brüel & Kjær publish a variety of technical literature which can be obtained free of charge.

The following literature is presently available:

Mechanical Vibration and Shock Measurements
(English, German, Russian)

Acoustic Noise Measurements (English, Russian), 2. edition
Strain Measurements

Architectural Acoustics (English)

Standards, formulae and charts (English)

Catalogs (several languages)

Product Data Sheets (English, German, French, Russian)

Furthermore, back copies of the Technical Review can be supplied as shown in the list above. Older issues may be obtained provided they are still in stock.

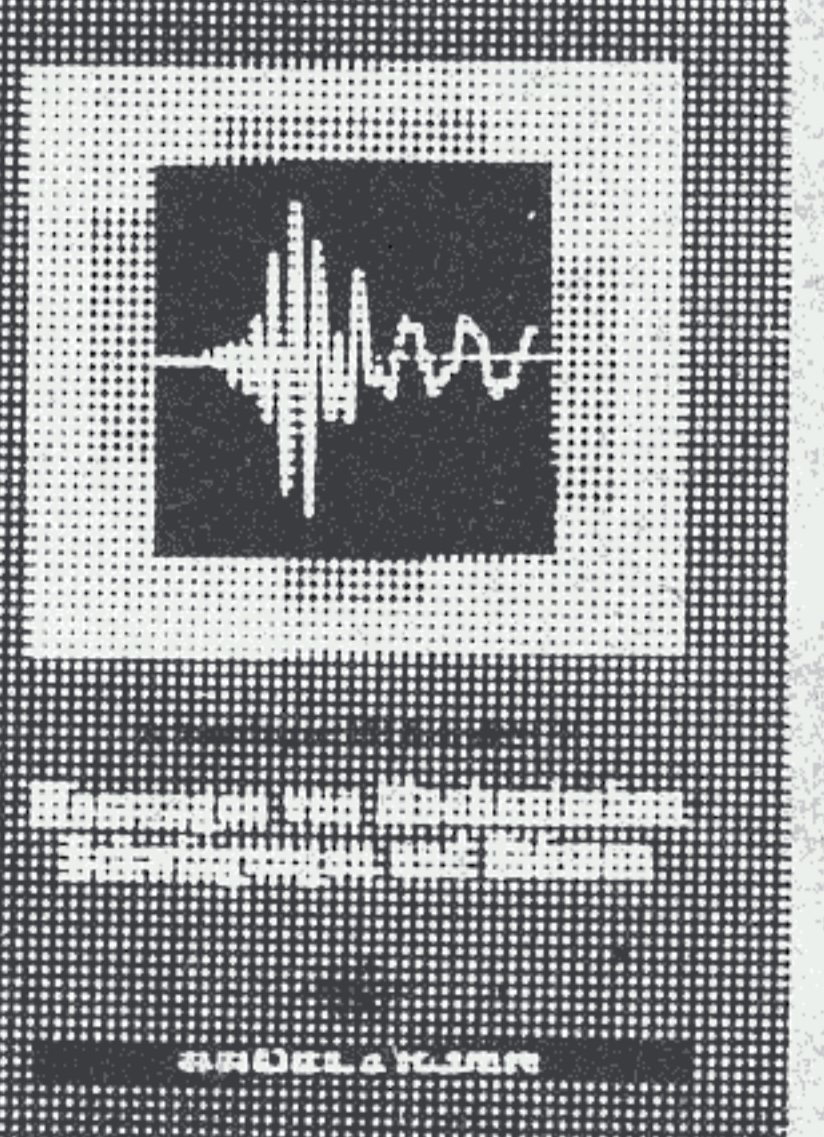
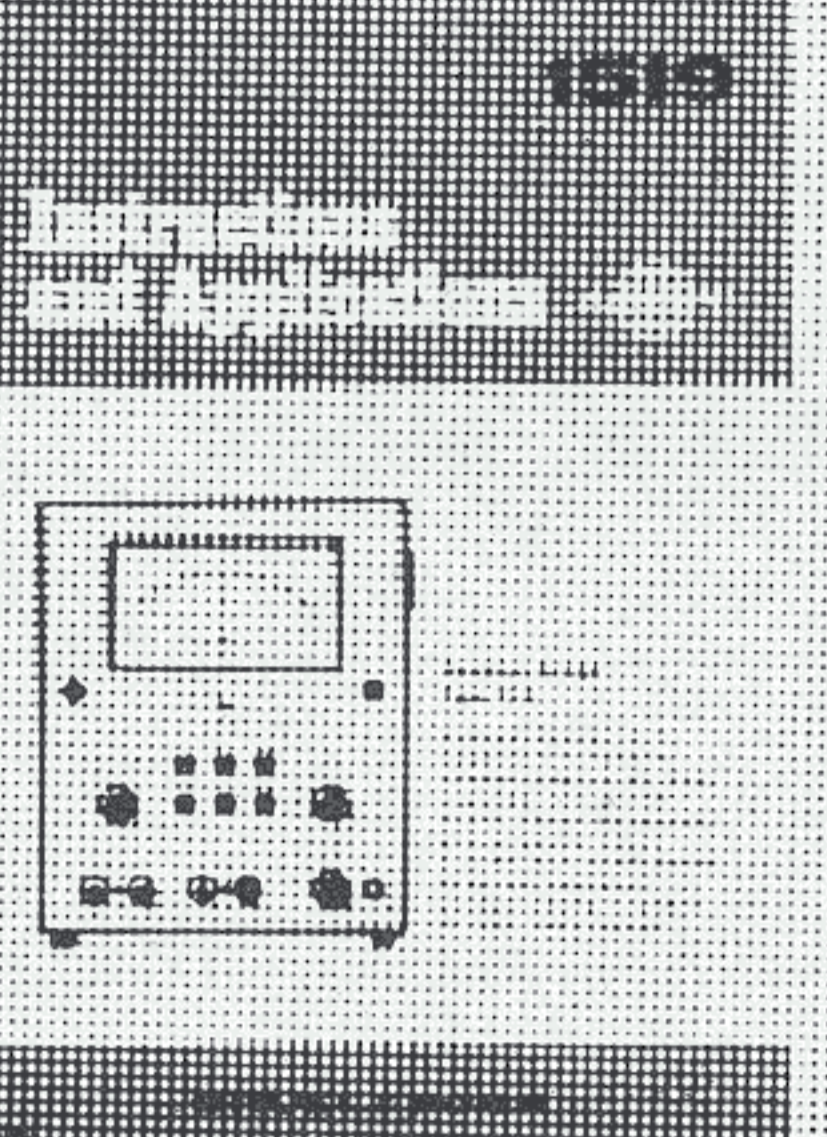
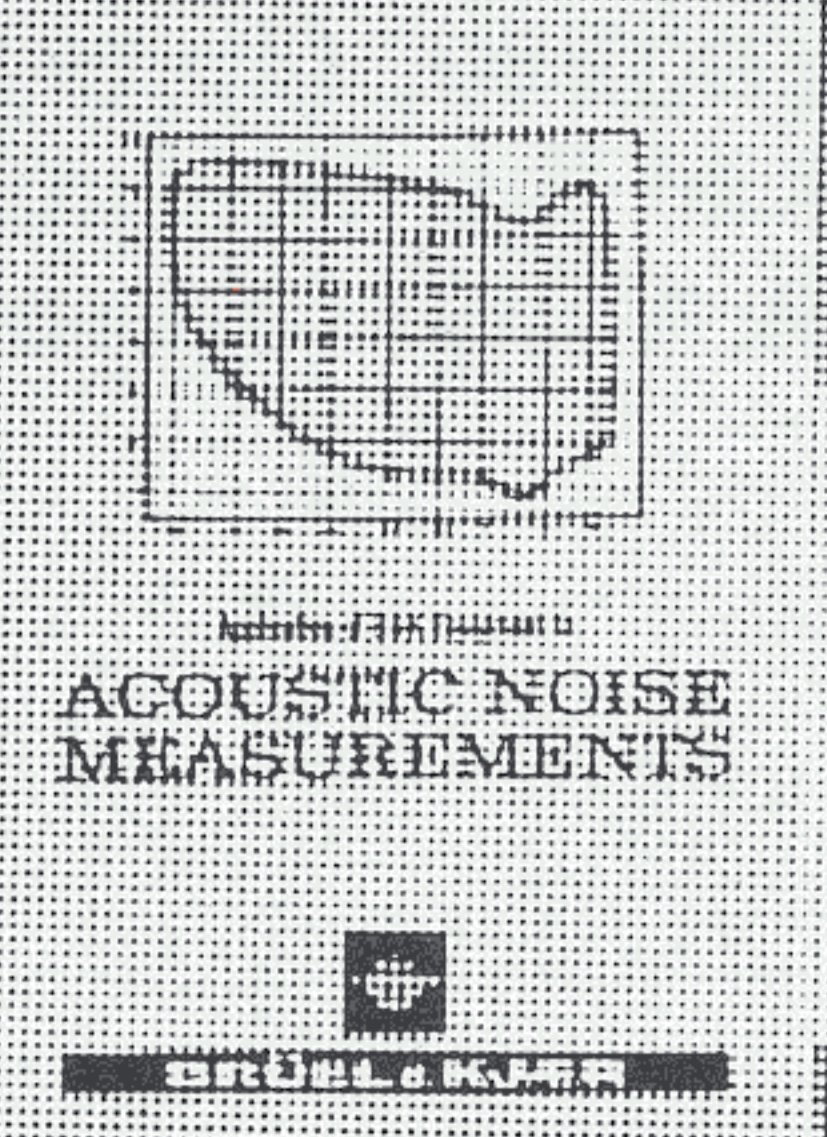
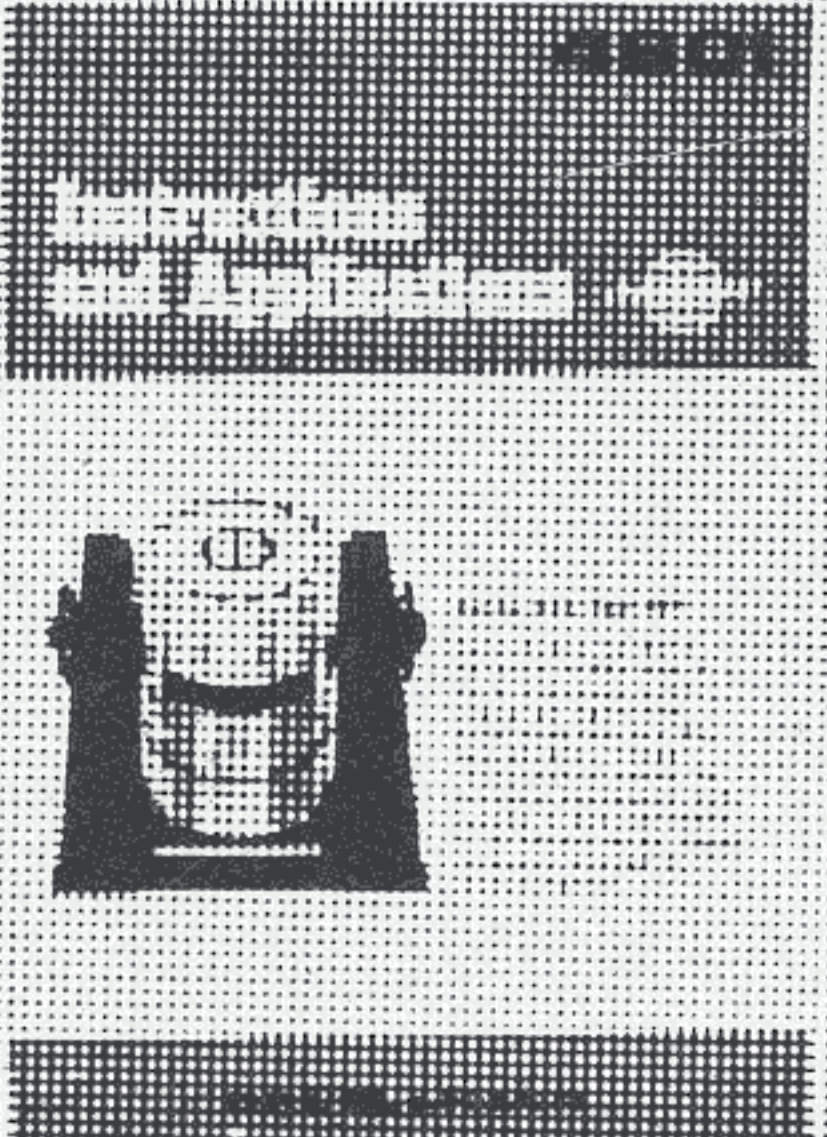
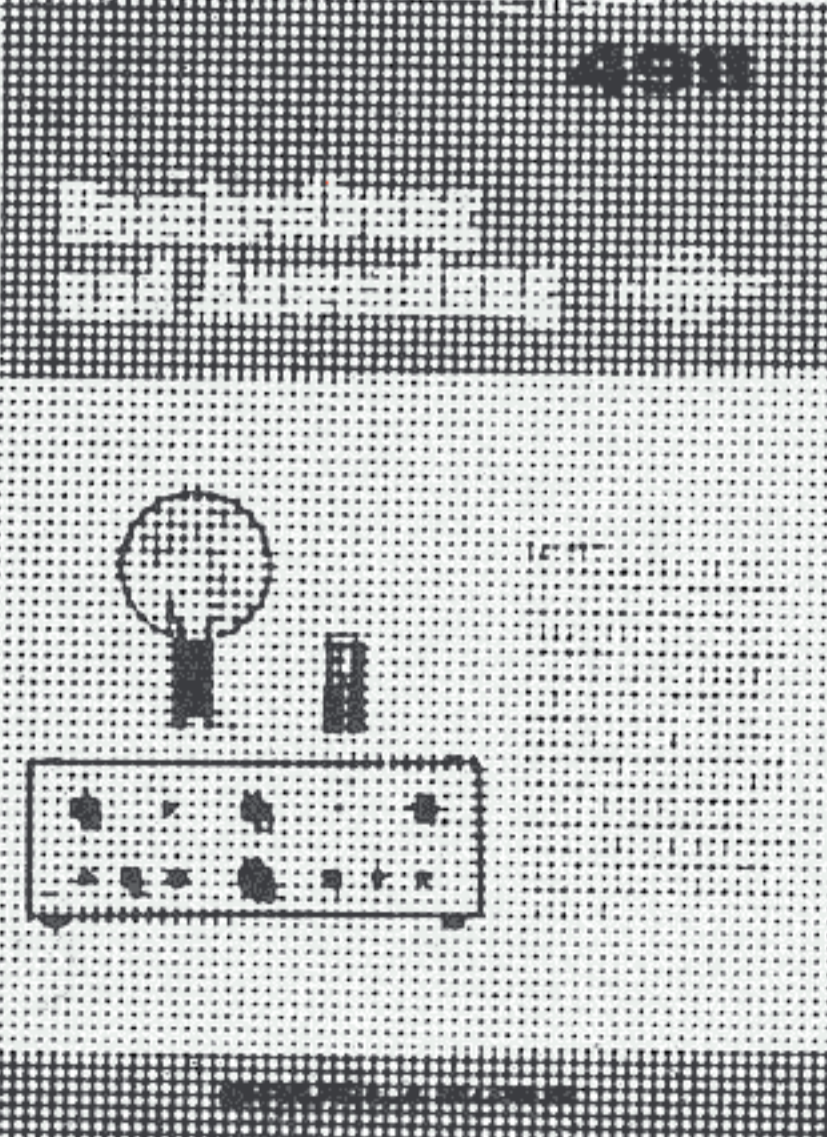
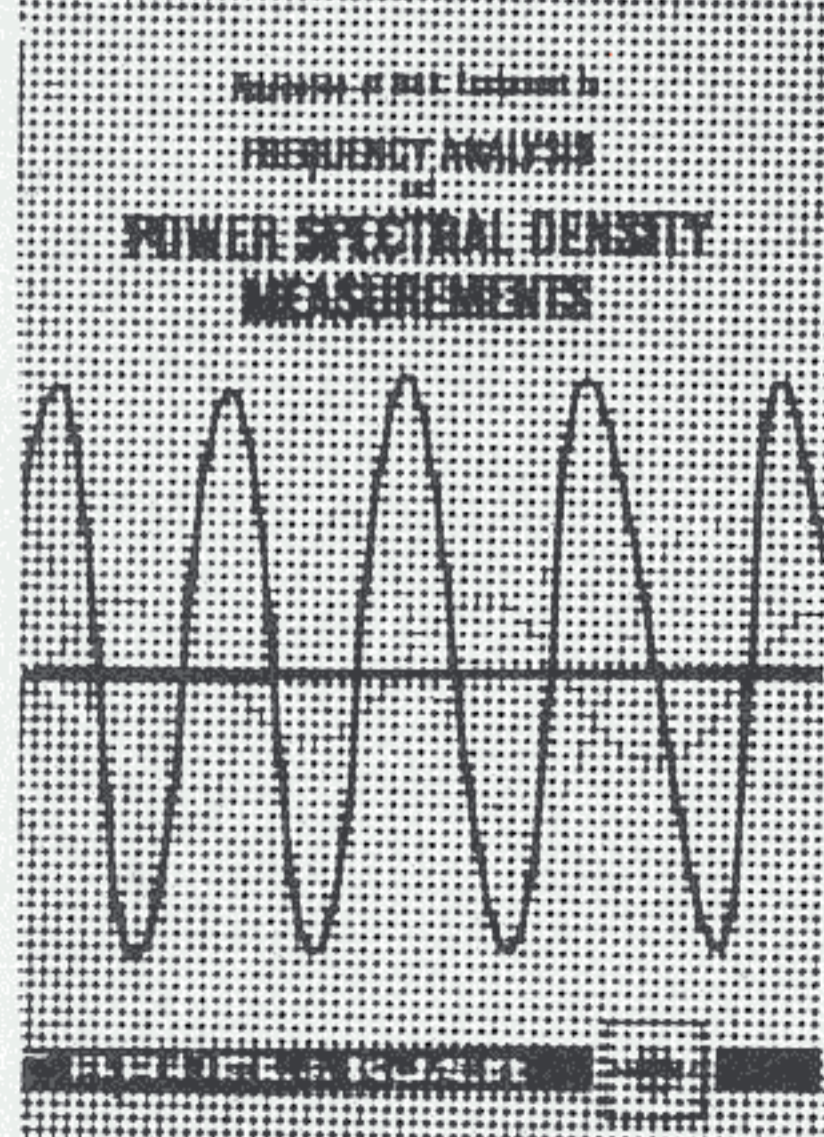
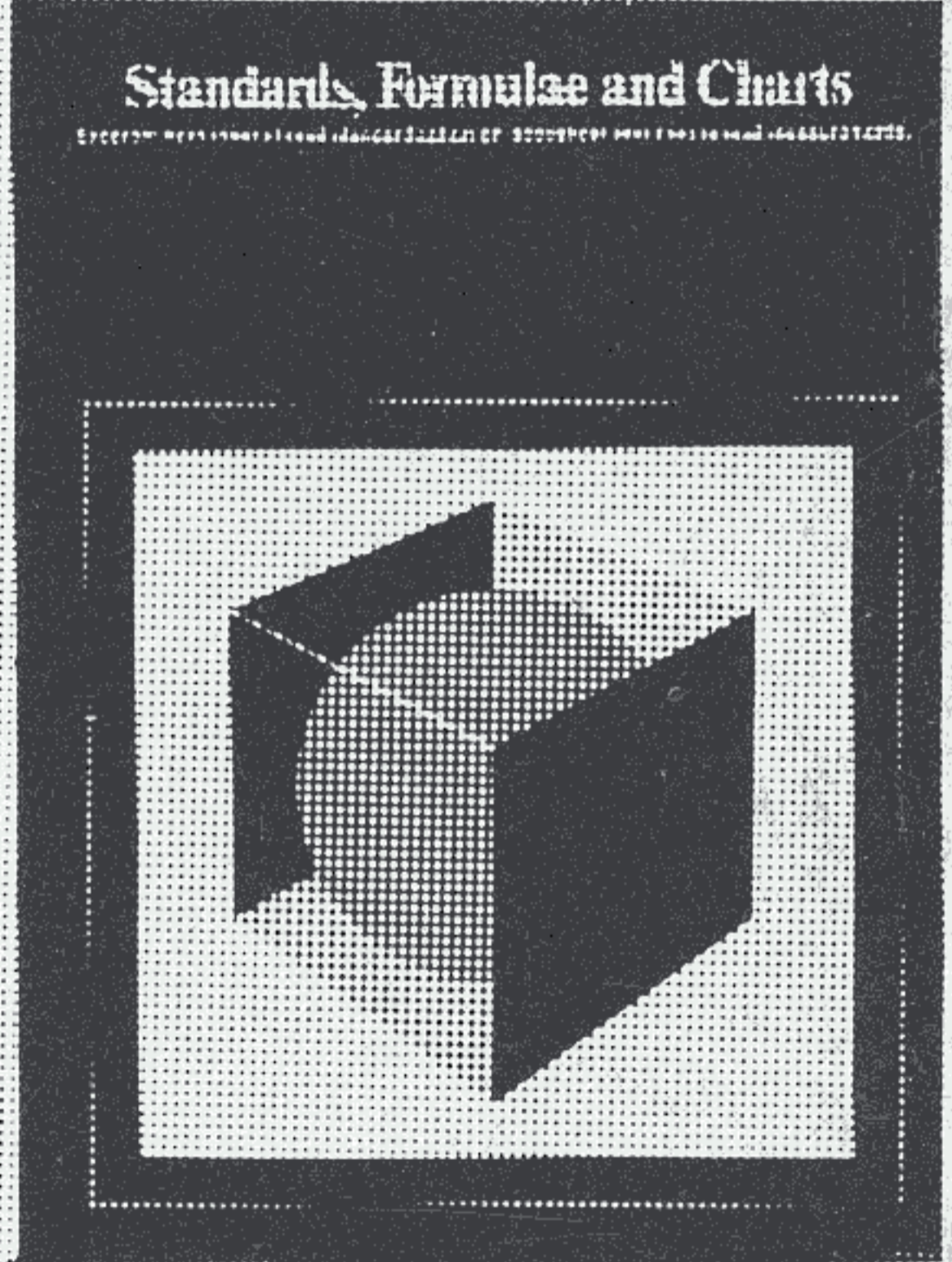
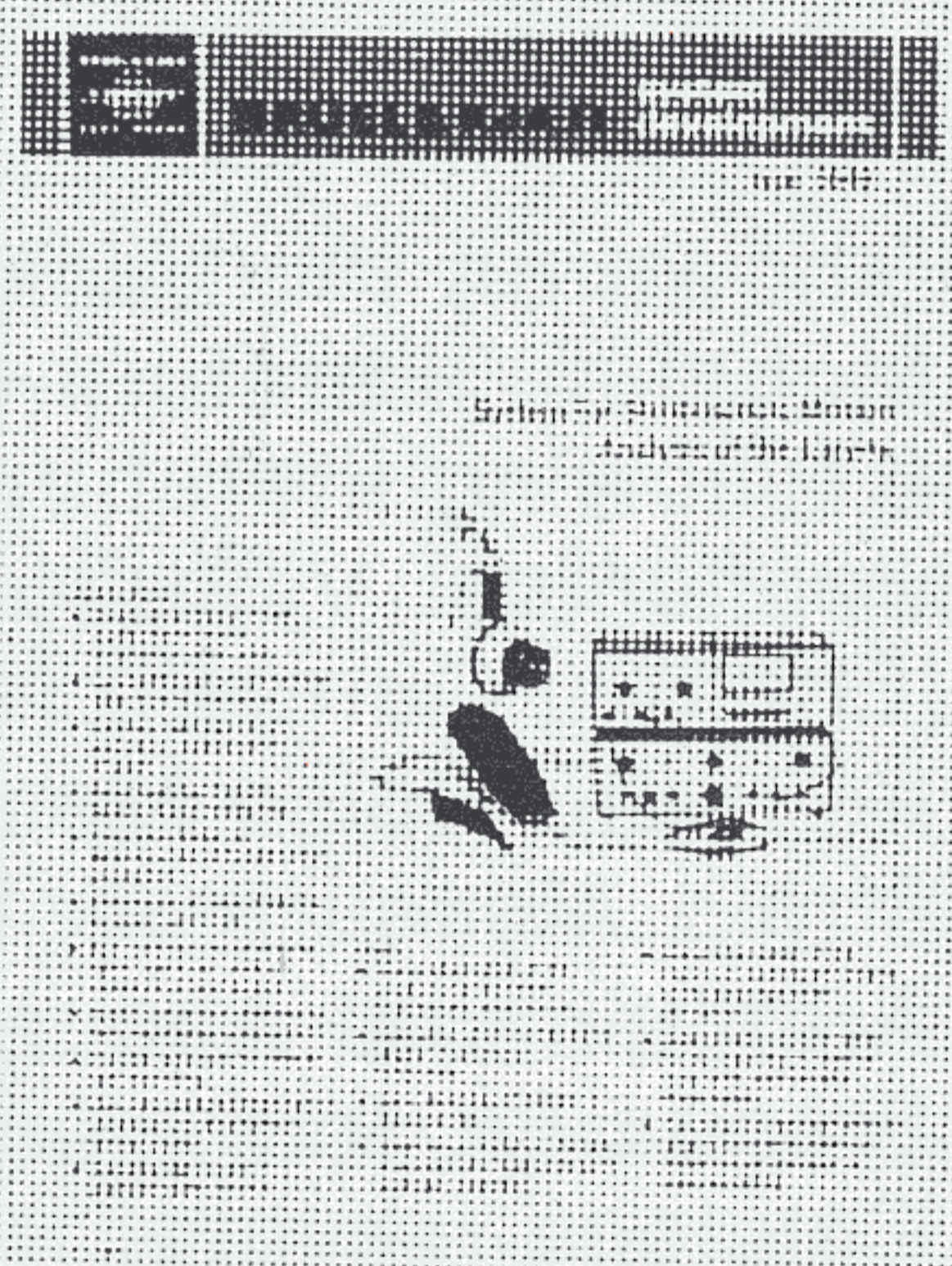
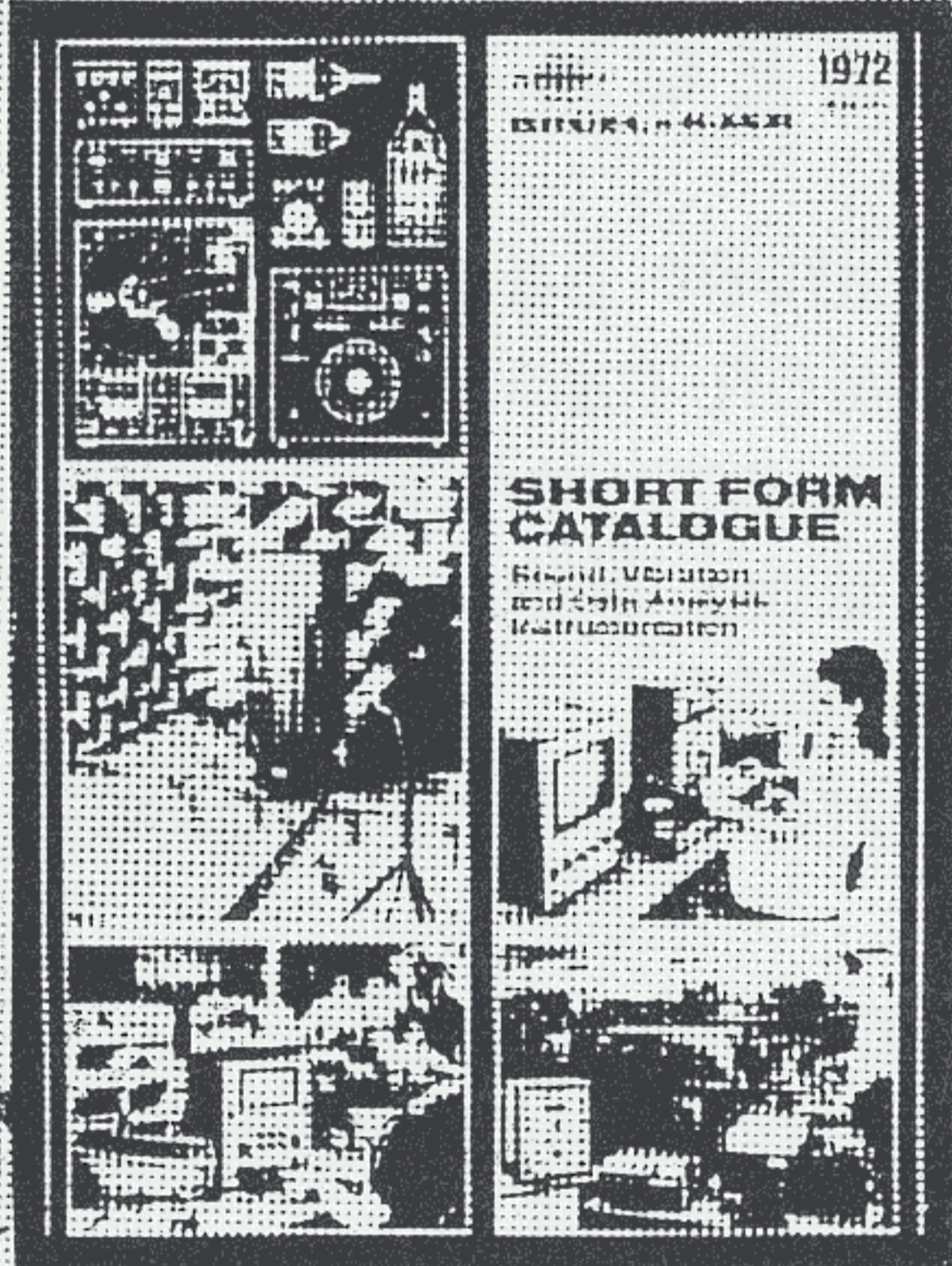
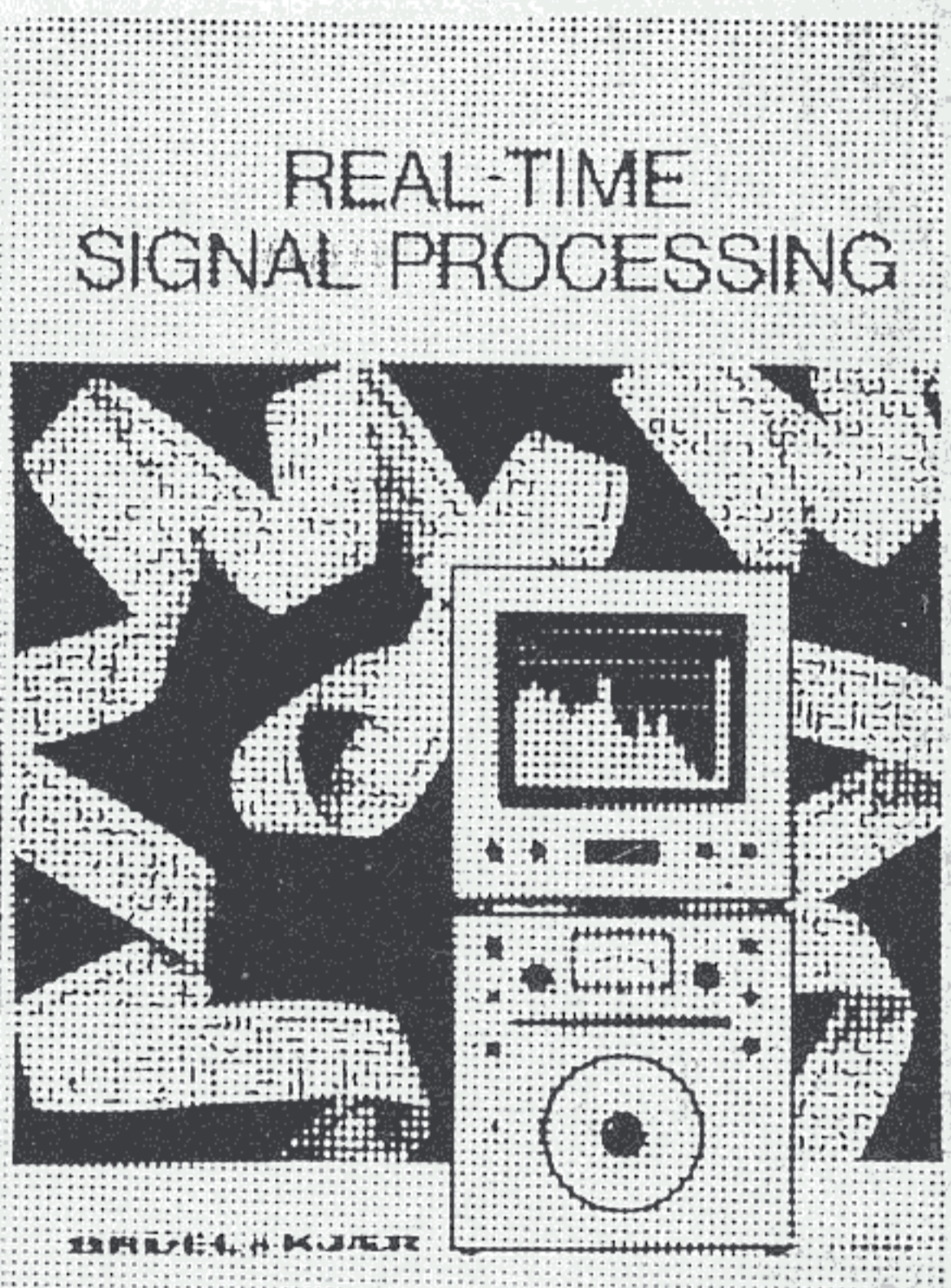
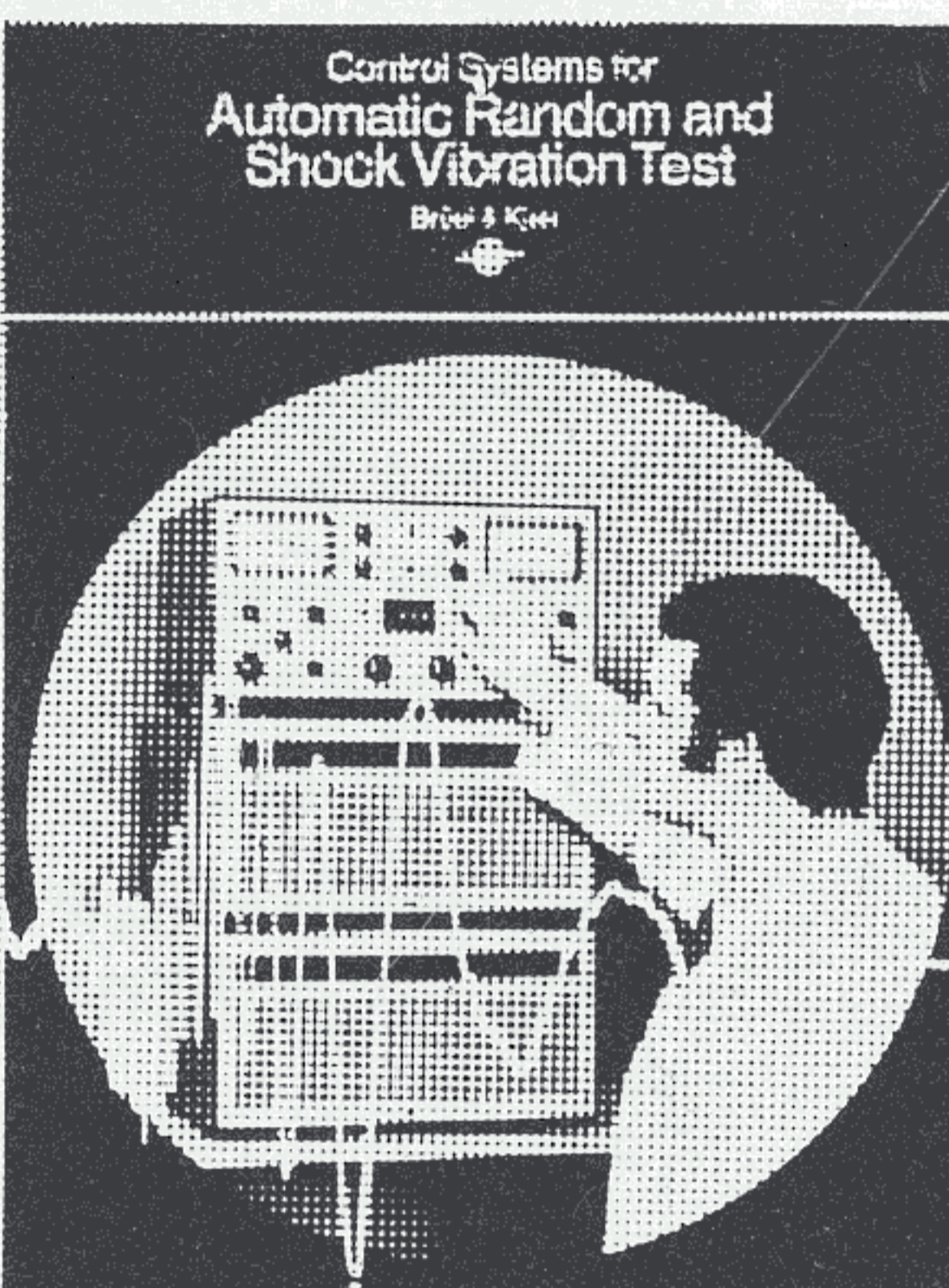
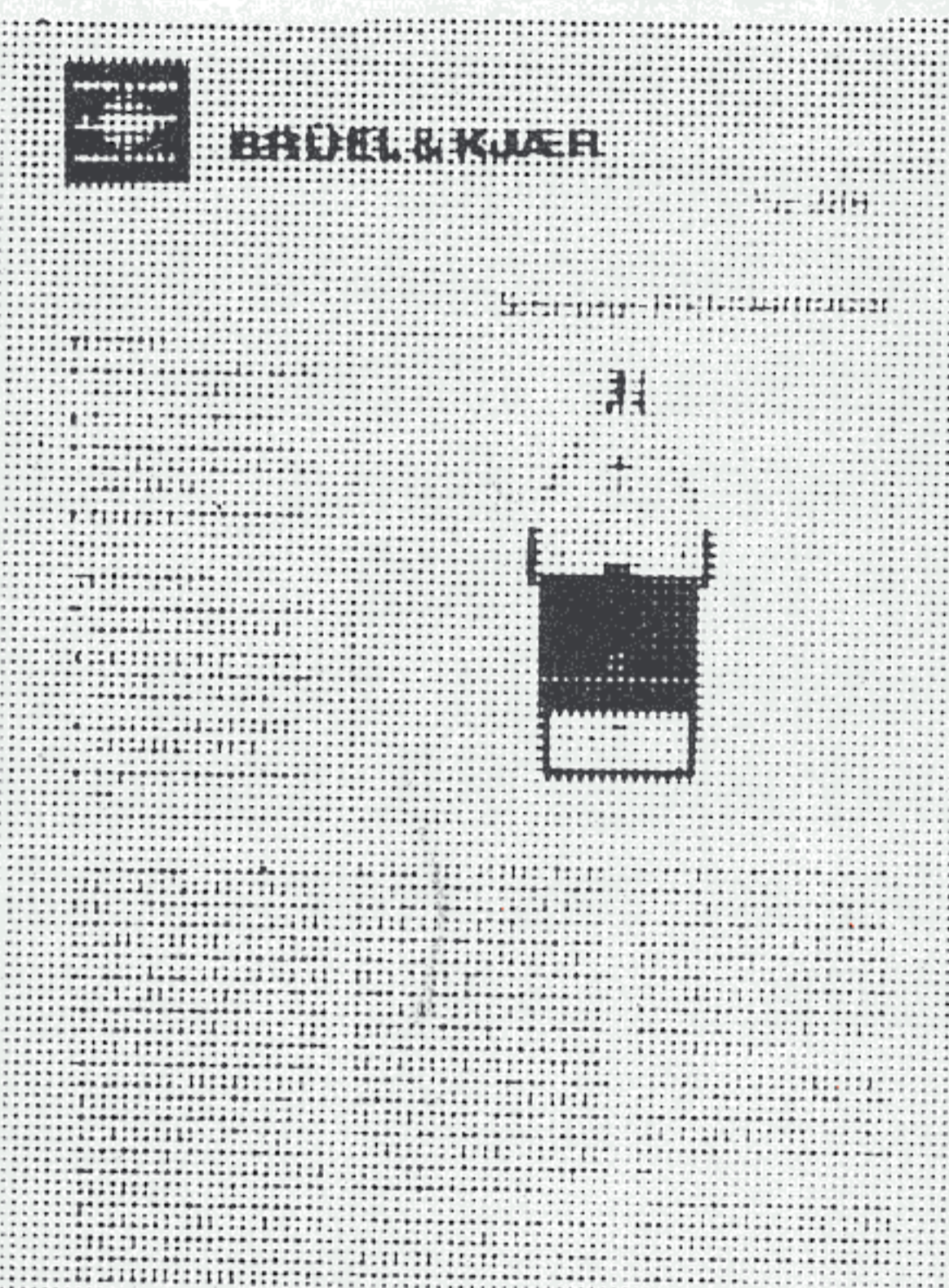
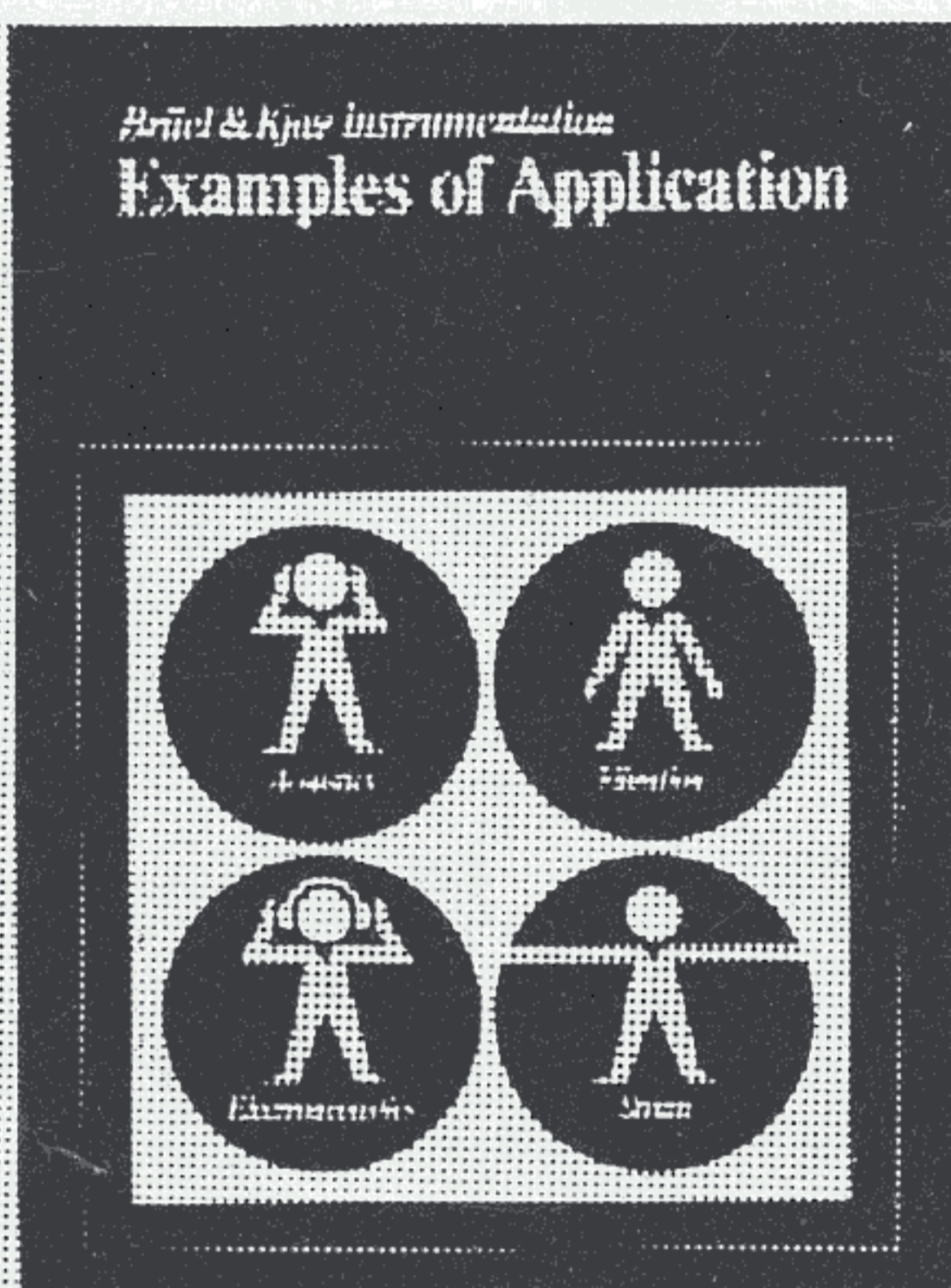
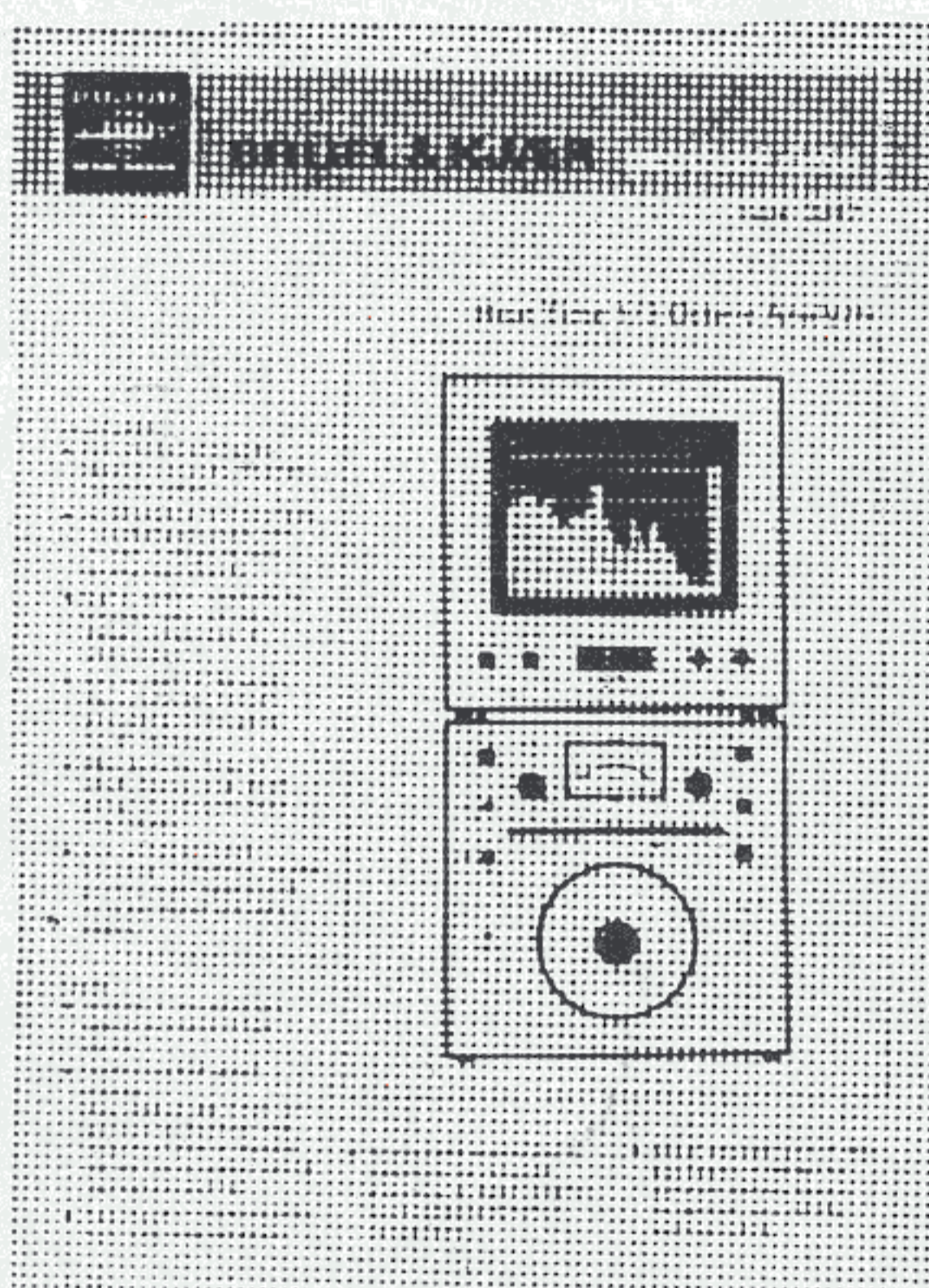

Brüel & Kjær

DK-2850 NÆRUM, DENMARK • Telephone: + 45 2 80 05 00 • Telex: 37316 bruka dk